

**Nidec**

All for dreams



*Power Installation Guide*

---

***Unidrive M/HS***  
***Frame 11E***

---

Part Number: 0478-0266-04

Issue: 4

## Original Instructions

For the purposes of compliance with the EU Machinery Directive 2006/42/EC, the English version of this manual is the Original Instructions. Manuals in other languages are Translations of the Original Instructions.

### Documentation

Manuals are available to download from the following locations: <http://www.drive-setup.com/ctdownloads>

The information contained in this manual is believed to be correct at the time of printing and does not form part of any contract. The manufacturer reserves the right to change the specification of the product and its performance, and the contents of the manual, without notice.

### Warranty and Liability

In no event and under no circumstances shall the manufacturer be liable for damages and failures due to misuse, abuse, improper installation, or abnormal conditions of temperature, dust, or corrosion, or failures due to operation outside the published ratings. The manufacturer is not liable for consequential and incidental damages. Contact the supplier of the drive for full details of the warranty terms.

### Environmental policy

Control Techniques Ltd operates an Environmental Management System (EMS) that conforms to the International Standard ISO 14001.

Further information on our Environmental Policy can be found at: <http://www.drive-setup.com/environment>

### Restriction of Hazardous Substances (RoHS)

The products covered by this manual comply with European and International regulations on the Restriction of Hazardous Substances including EU directive 2011/65/EU and the Chinese Administrative Measures for Restriction of Hazardous Substances in Electrical and Electronic Products.

### Disposal and Recycling (WEEE)



When electronic products reach the end of their useful life, they must not be disposed of along with domestic waste but should be recycled by a specialist recycler of electronic equipment. Control Techniques products are designed to be easily dismantled into their major component parts for efficient recycling. The majority of materials used in the product are suitable for recycling.

Product packaging is of good quality and can be re-used. Large products are packed in wooden crates. Smaller products are packaged in strong cardboard cartons which have a high recycled fibre content. Cartons can be re-used and recycled. Polythene, used in protective film and bags for wrapping the product, can be recycled. When preparing to recycle or dispose of any product or packaging, please observe local legislation and best practice.

### REACH legislation

EC Regulation 1907/2006 on the Registration, Evaluation, Authorisation and restriction of Chemicals (REACH) requires the supplier of an article to inform the recipient if it contains more than a specified proportion of any substance which is considered by the European Chemicals Agency (ECHA) to be a Substance of Very High Concern (SVHC) and is therefore listed by them as a candidate for compulsory authorisation.

Further information on our compliance with REACH can be found at: <http://www.drive-setup.com/reach>

### Registered Office

**Nidec Control Techniques Ltd**  
**The Gro**  
**Newtown**  
**Powys**  
**SY16 3BE**  
**UK**

Registered in England and Wales. Company Reg. No. 01236886.

## **Copyright**

The contents of this publication are believed to be correct at the time of printing. In the interests of a commitment to a policy of continuous development and improvement, the manufacturer reserves the right to change the specification of the product or its performance, or the contents of the guide, without notice.

All rights reserved. No parts of this guide may be reproduced or transmitted in any form or by any means, electrical or mechanical including photocopying, recording or by an information storage or retrieval system, without permission in writing from the publisher.

Copyright © July 2018 Nidec Control Techniques Ltd

---

# Contents

---

<b>1</b>	<b>Safety information</b>	<b>9</b>
1.1	Warnings, Cautions and Notes	9
1.2	Important safety information. Hazards. Competence of designers and installers	9
1.3	Responsibility	9
1.4	Compliance with regulations	9
1.5	Electrical hazards	10
1.6	Stored electrical charge	10
1.7	Mechanical hazards	10
1.8	Access to equipment	10
1.9	Environmental limits	10
1.10	Hazardous environments	11
1.11	Motor	11
1.12	Mechanical brake control	11
1.13	Adjusting parameters	11
1.14	Electromagnetic compatibility (EMC)	11
<b>2</b>	<b>Product information</b>	<b>12</b>
2.1	Introduction	12
2.2	Model number	12
2.3	Nameplate description	13
2.4	Ratings	14
2.5	Drive features	16
<b>3</b>	<b>Mechanical installation</b>	<b>18</b>
3.1	Safety information	18
3.2	Planning the installation	19
3.3	Terminal cover removal	21
3.4	Dimensions and mounting methods	23
3.5	Mounting brackets	26
3.6	Enclosure for standard drives	27
3.7	Enclosure design and drive ambient temperature	31
3.8	Heatsink fan operation	31
3.9	Enclosing standard drive for high environmental protection	32
3.10	External EMC filter	34
3.11	Terminal size and torque settings	36
3.12	Input line reactors	36
3.13	Routine maintenance	38
<b>4</b>	<b>Electrical installation</b>	<b>42</b>
4.1	Power connections	43
4.2	Ground connections	44
4.3	AC Supply requirements	45
4.4	Line reactors	46
4.5	24 Vdc supply	47
4.6	Low voltage operation	49
4.7	Heatsink fan supply	50
4.8	Motor requirements	50
4.9	Ratings	51
4.10	Output circuit and motor protection	51
4.11	Braking	55
4.12	Ground leakage	58
4.13	EMC (Electromagnetic compatibility)	59
<b>5</b>	<b>Technical data</b>	<b>74</b>
5.1	Drive technical data	74
5.2	Optional external EMC filters	87

<b>6</b>	<b>UL listing information</b>	<b>91</b>
6.1	UL file reference	91
6.2	Option modules, kits and accessories	91
6.3	Enclosure ratings	91
6.4	Mounting	91
6.5	Environment	92
6.6	Electrical Installation	92
6.7	Motor overload protection and thermal memory retention	92
6.8	Electrical supply	93
6.9	External Class 2 supply	93
6.10	Requirement for Transient Surge Suppression	93
6.11	Group Installation and Modular Drive Systems	93

# EU Declaration of Conformity

Control Techniques Ltd  
The Gro  
Newtown  
Powys  
UK  
SY16 3BE

This declaration is issued under the sole responsibility of the manufacturer. The object of the declaration is in conformity with the relevant Union harmonization legislation. The declaration applies to the variable speed drive products shown below:

Model number	Interpretation	Nomenclature aaaa - bbc ddddde
aaaa	Basic series	M100, M101, M200, M201, M300, M400, M600, M700, M701, M702, F300, H300, E200, E300, HS30, HS70, HS71, HS72, M000, RECT
bb	Frame size	01, 02, 03, 04, 05, 06, 07, 08, 09, 10, 11
c	Voltage rating	1 = 100 V, 2 = 200 V, 4 = 400 V, 5 = 575 V, 6 = 690 V
dddd	Current rating	Example 01000 = 100 A
e	Drive format	A = 6P Rectifier + Inverter (internal choke), D = Inverter, E = 6P Rectifier + Inverter (external choke), T = 12P Rectifier + Inverter (external choke)

The model number may be followed by additional characters that do not affect the ratings.

The variable speed drive products listed above have been designed and manufactured in accordance with the following European harmonized standards:

EN 61800-5-1:2007	Adjustable speed electrical power drive systems - Part 5-1: Safety requirements - Electrical, thermal and energy
EN 61800-3: 2004+A1:2012	Adjustable speed electrical power drive systems - Part 3: EMC requirements and specific test methods
EN 61000-6-2:2005	Electromagnetic compatibility (EMC) - Part 6-2: Generic standards - Immunity for industrial environments
EN 61000-6-4: 2007+A1:2011	Electromagnetic compatibility (EMC) - Part 6-4: Generic standards - Emission standard for industrial environments
EN 61000-3-2:2014	Electromagnetic compatibility (EMC) - Part 3-2: Limits for harmonic current emissions (equipment input current $\leq 16$ A per phase)
EN 61000-3-3:2013	Electromagnetic compatibility (EMC) - Part 3-3: Limitation of voltage changes, voltage fluctuations and flicker in public, low voltage supply systems, for equipment with rated current $\leq 16$ A per phase and not subject to conditional connection

EN 61000-3-2:2014 Applicable where input current < 16 A. No limits apply for professional equipment where input power  $\geq 1$  kW.

These products comply with the Restriction of Hazardous Substances Directive (2011/65/EU), the Low Voltage Directive (2014/35/EU) and the Electromagnetic Compatibility Directive (2014/30/EU).



**G Williams**  
**Vice President, Technology**  
**Date: 17th March 2016**

These electronic drive products are intended to be used with appropriate motors, controllers, electrical protection components and other equipment to form complete end products or systems. Compliance with safety and EMC regulations depends upon installing and configuring drives correctly, including using the specified input filters.

The drives must be installed only by professional installers who are familiar with requirements for safety and EMC. Refer to the Product Documentation. An EMC data sheet is available giving detailed information. The assembler is responsible for ensuring that the end product or system complies with all the relevant laws in the country where it is to be used.

# EU Declaration of Conformity (including 2006 Machinery Directive)

Control Techniques Ltd  
The Gro  
Newtown  
Powys  
UK  
SY16 3BE

This declaration is issued under the sole responsibility of the manufacturer. The object of the declaration is in conformity with the relevant Union harmonization legislation. The declaration applies to the variable speed drive products shown below:

Model number	Interpretation	Nomenclature aaaa - bbc dddde
aaaa	Basic series	M300, M400, M600, M700, M701, M702, F300, H300, E200, E300, HS30, HS70, HS71, HS72, M000, RECT
bb	Frame size	01, 02, 03, 04, 05, 06, 07, 08, 09, 10, 11
c	Voltage rating	1 = 100 V, 2 = 200 V, 4 = 400 V, 5 = 575 V, 6 = 690 V
ddddd	Current rating	Example 01000 = 100 A
e	Drive format	A = 6P Rectifier + Inverter (internal choke), D = Inverter, E = 6P Rectifier + Inverter (external choke), T = 12P Rectifier + Inverter (external choke)

The model number may be followed by additional characters that do not affect the ratings.

**This declaration relates to these products when used as a safety component of a machine. Only the Safe Torque Off function may be used for a safety function of a machine. None of the other functions of the drive may be used to carry out a safety function.**

These products fulfil all the relevant provisions of the Machinery Directive 2006/42/EC and the Electromagnetic Compatibility Directive (2014/30/EU).

EC type examination has been carried out by the following notified body:

TUV Rheinland Industrie Service GmbH  
Am Grauen Stein  
D-51105 Köln  
Germany

EC type-examination certificate numbers:

01/205/5270.01/14 dated 2014-11-11  
01/205/5387.01/15 dated 2015-01-29  
01/205/5383.02/15 dated 2015-04-21

Notified body identification number: 0035

The harmonized standards used are shown below:

EN 61800-5-1:2007	Adjustable speed electrical power drive systems - Part 5-1: Safety requirements - Electrical, thermal and energy
EN 61800-5-2:2007	Adjustable speed electrical power drive systems - Part 5-2: Safety requirements - Functional
EN ISO 13849-1:2008	Safety of Machinery, Safety-related parts of control systems, General principles for design
EN ISO 13849-2:2008	Safety of machinery, Safety-related parts of control systems. Validation
EN 61800-3: 2004+A1:2012	Adjustable speed electrical power drive systems - Part 3: EMC requirements and specific test methods
EN 62061:2005	Safety of machinery, Functional safety of safety related electrical, electronic and programmable electronic control systems

Person authorised to complete the technical file:

P Knight

Conformity Engineer

Newtown, Powys, UK



**G. Williams**

**Vice President, Technology**

**Date: 17th March 2016**

**Place: Newtown, Powys, UK**

#### **IMPORTANT NOTICE**

These electronic drive products are intended to be used with appropriate motors, controllers, electrical protection components and other equipment to form complete end products or systems. Compliance with safety and EMC regulations depends upon installing and configuring drives correctly, including using the specified input filters.

The drives must be installed only by professional installers who are familiar with requirements for safety and EMC. Refer to the Product Documentation. An EMC data sheet is available giving detailed information. The assembler is responsible for ensuring that the end product or system complies with all the relevant laws in the country where it is to be used.



# 1 Safety information

## 1.1 Warnings, Cautions and Notes



A Warning contains information which is essential for avoiding a safety hazard.



A Caution contains information which is necessary for avoiding a risk of damage to the product or other equipment.

**NOTE** A **Note** contains information, which helps to ensure correct operation of the product.

## 1.2 Important safety information. Hazards. Competence of designers and installers

This guide applies to products which control electric motors either directly (drives) or indirectly (controllers, option modules and other auxiliary equipment and accessories). In all cases the hazards associated with powerful electrical drives are present, and all safety information relating to drives and associated equipment must be observed.

Specific warnings are given at the relevant places in this guide.

Drives and controllers are intended as components for professional incorporation into complete systems. If installed incorrectly they may present a safety hazard. The drive uses high voltages and currents, carries a high level of stored electrical energy, and is used to control equipment which can cause injury. Close attention is required to the electrical installation and the system design to avoid hazards either in normal operation or in the event of equipment malfunction. System design, installation, commissioning/start-up and maintenance must be carried out by personnel who have the necessary training and competence. They must read this safety information and this guide carefully.

## 1.3 Responsibility

It is the responsibility of the installer to ensure that the equipment is installed correctly with regard to all instructions given in this guide. They must give due consideration to the safety of the complete system, so as to avoid the risk of injury both in normal operation and in the event of a fault or of reasonably foreseeable misuse.

The manufacturer accepts no liability for any consequences resulting from inappropriate, negligent or incorrect installation of the equipment.

## 1.4 Compliance with regulations

The installer is responsible for complying with all relevant regulations, such as national wiring regulations, accident prevention regulations and electromagnetic compatibility (EMC) regulations. Particular attention must be given to the cross-sectional areas of conductors, the selection of fuses or other protection, and protective ground (earth) connections.

This guide contains instructions for achieving compliance with specific EMC standards.

All machinery to be supplied within the European Union in which this product is used must comply with the following directives:

2006/42/EC Safety of machinery.

2014/30/EU: Electromagnetic Compatibility.

## 1.5 Electrical hazards

The voltages used in the drive can cause severe electrical shock and/or burns, and could be lethal. Extreme care is necessary at all times when working with or adjacent to the drive. Hazardous voltage may be present in any of the following locations:

- AC and DC supply cables and connections
- Output cables and connections
- Many internal parts of the drive, and external option units

Unless otherwise indicated, control terminals are single insulated and must not be touched.

The supply must be disconnected by an approved electrical isolation device before gaining access to the electrical connections.

The STOP and Safe Torque Off functions of the drive do not isolate dangerous voltages from the output of the drive or from any external option unit.

The drive must be installed in accordance with the instructions given in this guide. Failure to observe the instructions could result in a fire hazard.

## 1.6 Stored electrical charge

The drive contains capacitors that remain charged to a potentially lethal voltage after the AC supply has been disconnected. If the drive has been energized, the AC supply must be isolated at least ten minutes before work may continue.

## 1.7 Mechanical hazards

Careful consideration must be given to the functions of the drive or controller which might result in a hazard, either through their intended behaviour or through incorrect operation due to a fault. In any application where a malfunction of the drive or its control system could lead to or allow damage, loss or injury, a risk analysis must be carried out, and where necessary, further measures taken to reduce the risk - for example, an over-speed protection device in case of failure of the speed control, or a fail-safe mechanical brake in case of loss of motor braking.

**With the sole exception of the Safe Torque Off function, none of the drive functions must be used to ensure safety of personnel, i.e. they must not be used for safety-related functions.**

The Safe Torque Off function may be used in a safety-related application. The system designer is responsible for ensuring that the complete system is safe and designed correctly according to the relevant safety standards.

The design of safety-related control systems must only be done by personnel with the required training and experience. The Safe Torque Off function will only ensure the safety of a machine if it is correctly incorporated into a complete safety system. The system must be subject to a risk assessment to confirm that the residual risk of an unsafe event is at an acceptable level for the application.

## 1.8 Access to equipment

Access must be restricted to authorized personnel only. Safety regulations which apply at the place of use must be complied with.

## 1.9 Environmental limits

Instructions in this guide regarding transport, storage, installation and use of the equipment must be complied with, including the specified environmental limits. This includes temperature, humidity, contamination, shock and vibration. Drives must not be subjected to excessive physical force.

## 1.10 Hazardous environments

The equipment must not be installed in a hazardous environment (i.e. a potentially explosive environment).

## 1.11 Motor

The safety of the motor under variable speed conditions must be ensured.

To avoid the risk of physical injury, do not exceed the maximum specified speed of the motor.

Low speeds may cause the motor to overheat because the cooling fan becomes less effective, causing a fire hazard. The motor should be installed with a protection thermistor. If necessary, an electric forced vent fan should be used.

The values of the motor parameters set in the drive affect the protection of the motor. The default values in the drive must not be relied upon. It is essential that the correct value is entered in the Motor Rated Current parameter.

## 1.12 Mechanical brake control

Any brake control functions are provided to allow well co-ordinated operation of an external brake with the drive. While both hardware and software are designed to high standards of quality and robustness, they are not intended for use as safety functions, i.e. where a fault or failure would result in a risk of injury. In any application where the incorrect operation of the brake release mechanism could result in injury, independent protection devices of proven integrity must also be incorporated.

## 1.13 Adjusting parameters

Some parameters have a profound effect on the operation of the drive. They must not be altered without careful consideration of the impact on the controlled system. Measures must be taken to prevent unwanted changes due to error or tampering.

## 1.14 Electromagnetic compatibility (EMC)

Installation instructions for a range of EMC environments are provided in the relevant Power Installation Guide. If the installation is poorly designed or other equipment does not comply with suitable standards for EMC, the product might cause or suffer from disturbance due to electromagnetic interaction with other equipment. It is the responsibility of the installer to ensure that the equipment or system into which the product is incorporated complies with the relevant EMC legislation in the place of use.

# 2 Product information

## 2.1 Introduction

This guide provides the information necessary to install the following drive models:

*Unidrive Mxxx* frame 11E

*Unidrive HSxx* frame 11E

This guide focuses on the drive power section, for example: electrical installation of the supply / motor cables and mechanical installation of the drive.

For information about the drive control section, for example: parameter set up information, control and encoder connections please refer to the *Control User Guide*.

## 2.2 Model number

The model number for the *Unidrive M/HS* product range is formed as illustrated below:

**Figure 2-1 Model number**

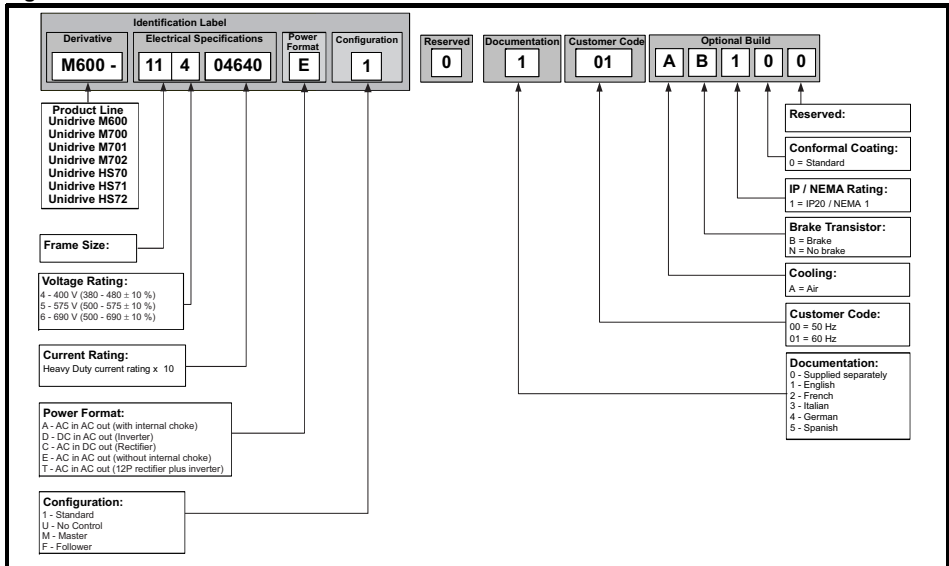

## 2.3 Nameplate description

Figure 2-2 Typical drive rating labels

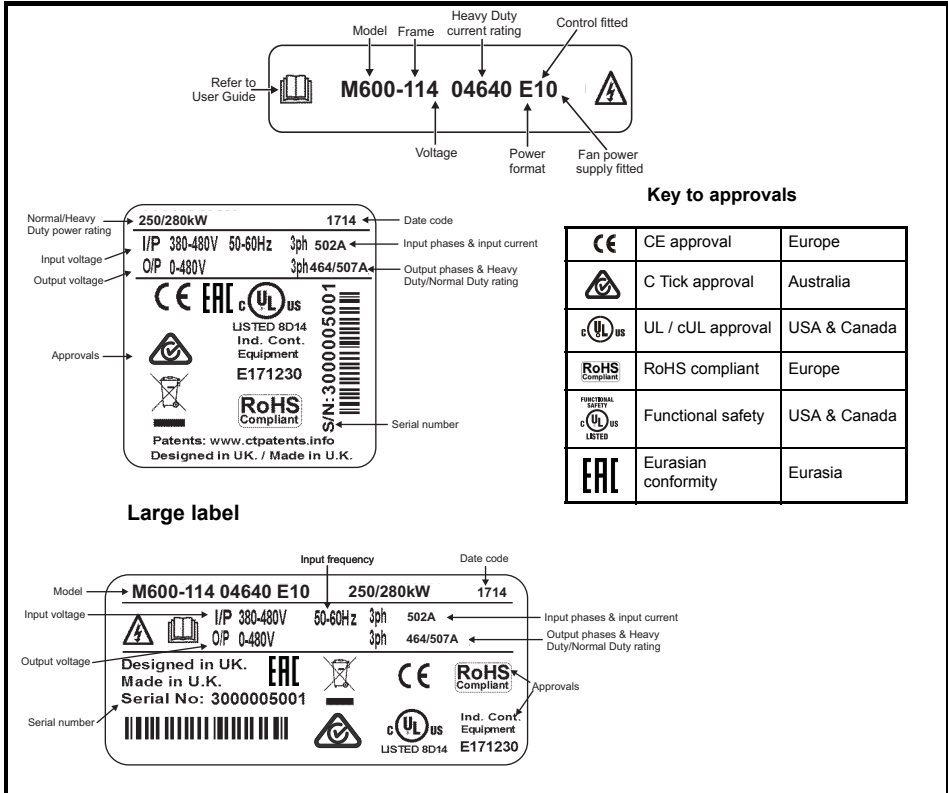

Refer to Figure 2-1 *Model number* on page 12 for further information relating to the labels.

### NOTE Date code format

The date code is four numbers. The first two numbers indicate the year and the remaining numbers indicate the week of the year in which the drive was built.

#### Example:

A date code of **1710** would correspond to week 10 of year 2017.

## 2.4 Ratings



### Fuses

The AC supply to the drive must be installed with suitable protection against overload and short-circuits. The following section shows recommended fuse ratings. Failure to observe this requirement will cause risk of fire.

**NOTE** Nominal cables sizes below are based on the cable installation method C (ref: IEC60364-5-52:2001) unless otherwise specified, and are provided as a guide only. Ensure cables used suit local wiring regulations.

**Table 2-1 400 V drive ratings, cable sizes and fuse ratings @ 2 kHz**

Model	Max. cont. input current	Fuse				Nominal cable size				Normal Duty			Heavy Duty		
		IEC		UL		European		USA		Max. cont. output current	Nom power @ 400 V	Motor power @ 460 V	Max. cont. output current	Nom power @ 400 V	Motor power @ 460 V
		3ph	Nom	Class	Nom	Class	Input	Output	Input						
		A	A	Class	A	Class	mm <sup>2</sup>	mm <sup>2</sup>	AWG/kcmil	AWG/kcmil	A	kW	hp	A	kW
11403770	449	500	gR	600	HSJ	2x150	2x150	2x300 kcmil	2x300 kcmil	437	225	350	377	185	300
11404170	492	500		600		2x150	2x185	2x300 kcmil	2x350 kcmil	487	250	400	417	200	350
11404640	539	550		600		2x150	2x185	2x300 kcmil	2x350 kcmil	507	280	450	464	250	400

**Table 2-2 575 V drive ratings, cable sizes and fuse ratings @ 2 kHz**

Model	Max. cont. input current	Fuse				Nominal cable size				Normal Duty			Heavy Duty		
		IEC		UL		European		USA		Max. cont. output current	Nom power @ 575 V	Motor power @ 575 V	Max. cont. output current	Nom power @ 575 V	Motor power @ 575 V
		3ph	Nom	Class	Nom	Class	Input	Output	Input						
		A	A	Class	A	Class	mm <sup>2</sup>	mm <sup>2</sup>	AWG/kcmil	AWG/kcmil	A	kW	hp	A	kW
11502000	265	400	gR	400	HSJ	2x120	185	2x4/0 AWG	350 kcmil	248	185	250	200	150	200
11502540	310	400		400		2x120	2x120	2x4/0 AWG	2x4/0 AWG	288	225	300	254	185	250
11502850	338	400		400		2x120	2x120	2x4/0 AWG	2x4/0 AWG	315	250	350	285	225	300

**NOTE** Refer to Chapter 5.1 *Drive technical data* on page 74 for peak current data.

**Table 2-3 690 V drive ratings, cable sizes and fuse ratings @ 2 kHz**

Model	Max. cont. input current	Fuse				Nominal cable size				Normal Duty			Heavy Duty		
		IEC		UL		European		USA		Max. cont. output current	Nom power @ 690 V	Motor power @ 690 V	Max. cont. output current	Nom power @ 690 V	Motor power @ 690 V
		3ph	Nom	Nom	Class	Input	Output	Input	Output						
		A	A	A	Class	mm <sup>2</sup>	mm <sup>2</sup>	AWG	AWG						
11602100	256	400	gR	400	HSJ	2x120	185	2x4/0 AWG	2x4/0 AWG	225	200	250	210	185	250
11602380	302	400		400		2x120	2x120	2x4/0 AWG	2x4/0 AWG	275	250	300	238	200	250
11602630	329	400		400		2x120	2x120	2x4/0 AWG	2x4/0 AWG	305	280	400	263	250	300

**Table 2-4 Protective ground cable ratings**

Input phase conductor size	Minimum ground conductor size
≤ 10 mm <sup>2</sup>	Either 10 mm <sup>2</sup> or two conductors of the same cross-sectional area as the input phase conductor
> 10 mm <sup>2</sup> and ≤ 16 mm <sup>2</sup>	The same cross-sectional area as the input phase conductor
> 16 mm <sup>2</sup> and ≤ 35 mm <sup>2</sup>	16 mm <sup>2</sup>
> 35 mm <sup>2</sup>	Half of the cross-sectional area of the input phase conductor

**Typical short term overload limits**

The maximum percentage overload limit changes depending on the selected motor. Variations in motor rated current, motor power factor and motor leakage inductance all result in changes in the maximum possible overload. Typical values are shown in the table below:

**Table 2-5 Typical overload limits**

Operating mode	RFC from cold	RFC from 100 %	Open loop from cold	Open loop from 100 %
Normal Duty overload with motor rated current = drive rated current	110 % for 165 s	110 % for 9 s	110 % for 165 s	110 % for 9 s
Heavy Duty overload with motor rated current = drive rated current	175 % for 42 s	175 % for 5 s	150 % for 60 s	150 % for 7 s

Generally the drive rated current is higher than the matching motor rated current allowing a higher level of overload than the default setting.

The time allowed in the overload region is proportionally reduced at very low output frequency on some drive ratings.

**NOTE** The maximum overload level which can be attained is independent of the speed.

**Output current**

The continuous output current ratings given on the rating label are for maximum 40 °C (104 °F), 1000 m altitude and 2 kHz switching frequency. Derating is required for higher switching frequencies, ambient temperatures >40 °C (104 °F) and higher altitude. For further information, refer to Chapter 5.1 *Drive technical data* on page 74.

**Input current**

The input current is affected by the supply voltage and impedance. The input current given on the rating label is the typical input current and is stated for a balanced supply.

## 2.5 Drive features

Figure 2-3 Features of the drive

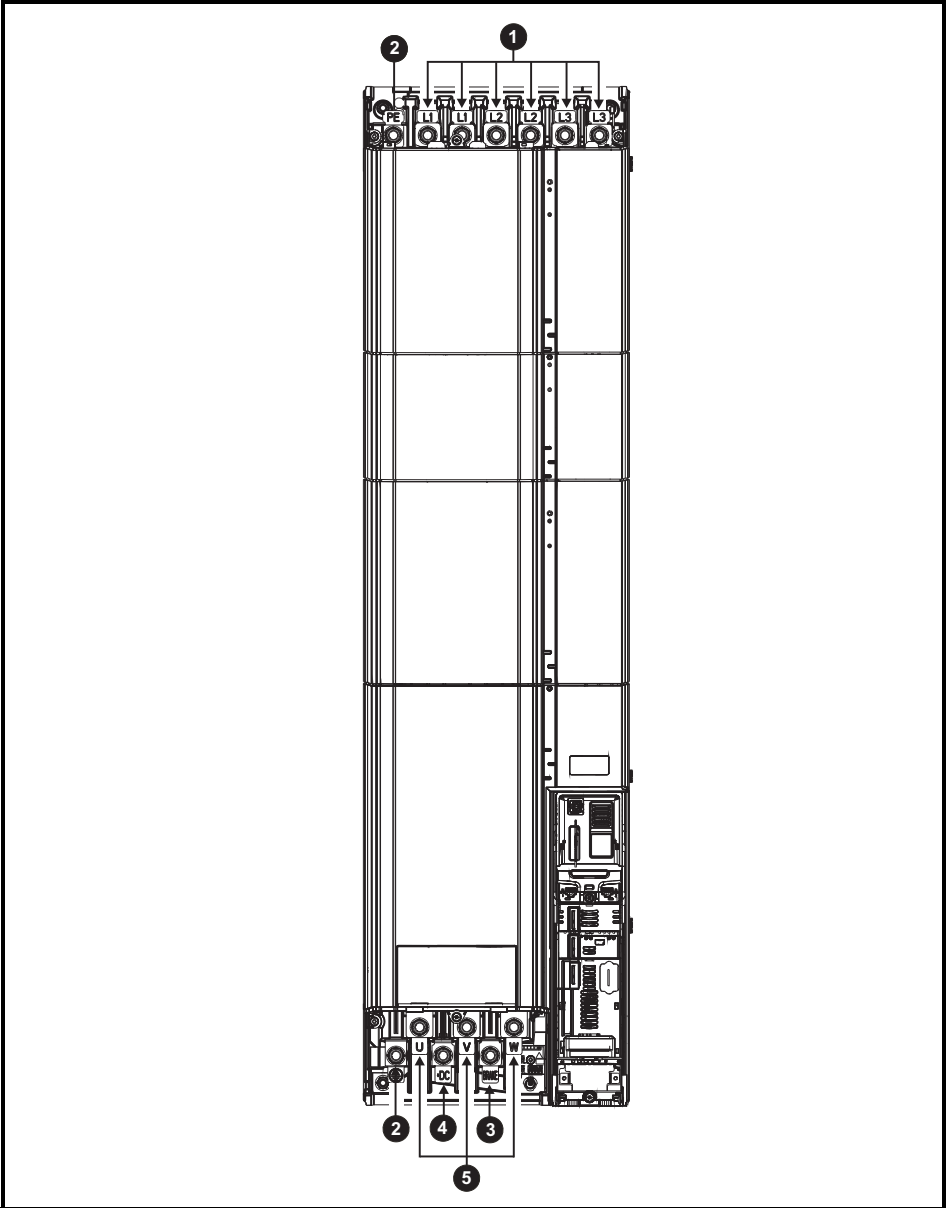

### Key

1. AC supply connections\* 2. Ground connections 3. Braking terminal 4. DC bus + 5. Motor connections







\* Common AC supply connections are internally linked on 6 pulse drives

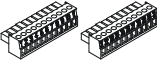

## 2.5.1 Items supplied with the drive

The drive is supplied with a copy of the *Power Installation Guide* and a copy of the *Control Getting Started Guide*, a safety information booklet, the Certificate of Quality and an accessory kit box including the items shown in Table 2-6.

**Table 2-6 Parts supplied with the drive**

Description	
Control connectors (1 x 1 to 11) (1 x 21 to 31)	 x 1*      x 1*
Control connectors (1 x 1 to 13)	 x 1**
Relay connector	 x 1
24 V power supply connector	 x 1
Grounding bracket	 x 1
Surface mounting brackets	 x 2                      x 1

\* Supplied with *Unidrive M600 / M700 / M701* and *HS70 / HS71* only.

\*\* Supplied with *Unidrive M702* and *HS72* only.

---

## 3 Mechanical installation

---

### 3.1 Safety information



#### Follow the instructions

The mechanical and electrical installation instructions must be adhered to. Any questions or doubt should be referred to the supplier of the equipment. It is the responsibility of the owner or user to ensure that the installation of the drive and any external option unit, and the way in which they are operated and maintained, comply with the requirements of the Health and Safety at Work Act in the United Kingdom or applicable legislation and regulations and codes of practice in the country in which the equipment is used.



#### Stored charge

The drive contains capacitors that remain charged to a potentially lethal voltage after the AC supply has been disconnected. If the drive has been energized, the AC supply must be isolated at least ten minutes before work may continue.

Normally, the capacitors are discharged by an internal resistor. Under certain, unusual fault conditions, it is possible that the capacitors may fail to discharge, or be prevented from being discharged by a voltage applied to the output terminals. If the drive has failed in a manner that causes the display to go blank immediately, it is possible the capacitors will not be discharged. In this case, consult Nidec Industrial Automation or their authorized distributor.



#### Competence of the installer

The drive must be installed by professional assemblers who are familiar with the requirements for safety and EMC. The assembler is responsible for ensuring that the end product or system complies with all the relevant laws in the country where it is to be used.



#### Enclosure

The drive is intended to be mounted in an enclosure which prevents access except by trained and authorized personnel, and which prevents the ingress of contamination. It is designed for use in an environment classified as pollution degree 2 in accordance with IEC 60664-1. This means that only dry, non-conducting contamination is acceptable.

## 3.2 Planning the installation

The following considerations must be made when planning the installation:

### 3.2.1 Access

Access must be restricted to authorized personnel only. Safety regulations which apply at the place of use must be complied with.

The IP (Ingress Protection) rating of the drive is installation dependent. For further information, refer to section 3.9 *Enclosing standard drive for high environmental protection* on page 32.

### 3.2.2 Environmental protection

The drive must be protected from:

- Moisture, including dripping water or spraying water and condensation. An anti-condensation heater may be required, which must be switched off when the drive is running.
- Contamination with electrically conductive material
- Contamination with any form of dust which may restrict the fan, or impair airflow over various components
- Temperature beyond the specified operating and storage ranges
- Corrosive gasses

**NOTE** During installation it is recommended that the vents on the drive are covered to prevent debris (e.g. wire off-cuts) from entering the drive.

### 3.2.3 Cooling

The heat produced by the drive must be removed without its specified operating temperature being exceeded. Note that a sealed enclosure gives much reduced cooling compared with a ventilated one, and may need to be larger and/or use internal air circulating fans.

For further information, refer to section 3.6 *Enclosure for standard drives* on page 27.

### 3.2.4 Electrical safety

The installation must be safe under normal and fault conditions. Electrical installation instructions are given in Chapter 4 *Electrical installation* on page 42.

### 3.2.5 Fire protection

The drive enclosure is not classified as a fire enclosure. A separate fire enclosure must be provided. For installation in the USA, a NEMA 12 enclosure is suitable.

For installation outside the USA, the following (based on IEC 62109-1, standard for PV inverters) is recommended.

Enclosure can be metal and/or polymeric, polymer must meet requirements which can be summarized for larger enclosures as using materials meeting at least UL 94 class 5VB at the point of minimum thickness.

Air filter assemblies to be at least class V-2.

The location and size of the bottom shall cover the area shown in Figure 3-1. Any part of the side which is within the area traced out by the 5° angle is also considered to be part of the bottom of the fire enclosure.

**Figure 3-1 Fire enclosure bottom layout**

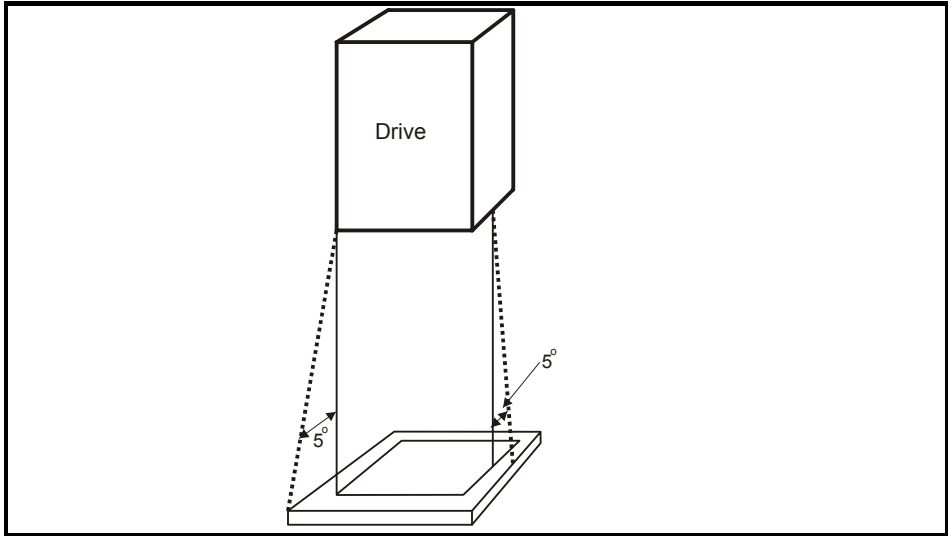

The bottom, including the part of the side considered to be part of the bottom, must be designed to prevent escape of burning material - either by having no openings or by having a baffle construction. This means that openings for cables etc. must be sealed with materials meeting the 5VB requirement, or else have a baffle above. See Figure 3-2 for acceptable baffle construction. This does not apply for mounting in an enclosed electrical operating area (restricted access) with concrete floor.

**Figure 3-2 Fire enclosure baffle construction**

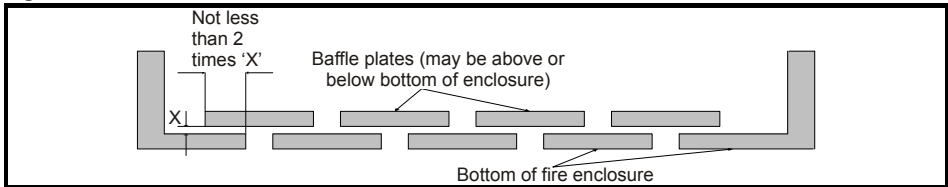

### 3.2.6 Electromagnetic compatibility

Variable speed drives are powerful electronic circuits which can cause electromagnetic interference if not installed correctly with careful attention to the layout of the wiring.

Some simple routine precautions can prevent disturbance to typical industrial control equipment.

If it is necessary to meet strict emission limits, or if it is known that electromagnetically sensitive equipment is located nearby, then full precautions must be observed. In-built into the drive, is an internal EMC filter, which reduces emissions under certain conditions. If these conditions are exceeded, then the use of an external EMC filter may be required at the drive inputs, which must be located very close to the drives. Space must be made available for the filters and allowance made for carefully segregated wiring. Both levels of precautions are covered in section 4.13 *EMC (Electromagnetic compatibility) on page 59.*

### 3.2.7 Hazardous areas

The drive must not be located in a classified hazardous area unless it is installed in an approved enclosure and the installation is certified.

### 3.3 Terminal cover removal



#### Isolation device

The AC supply must be disconnected from the drive using an approved isolation device before any cover is removed from the drive or before any servicing work is performed.



#### Stored charge

The drive contains capacitors that remain charged to a potentially lethal voltage after the AC supply has been disconnected. If the drive has been energized, the AC supply must be isolated at least ten minutes before work may continue.

Normally, the capacitors are discharged by an internal resistor. Under certain, unusual fault conditions, it is possible that the capacitors may fail to discharge, or be prevented from being discharged by a voltage applied to the output terminals. If the drive has failed in a manner that causes the display to go blank immediately, it is possible the capacitors will not be discharged. In this case, consult Nidec Industrial Automation or their authorized distributor.

#### 3.3.1 Removing the terminal covers

Unidrive M / Unidrive HS size 11E drives are installed with three terminal covers: Control, input and output terminal covers.

**Figure 3-3 Location and identification of terminal covers**

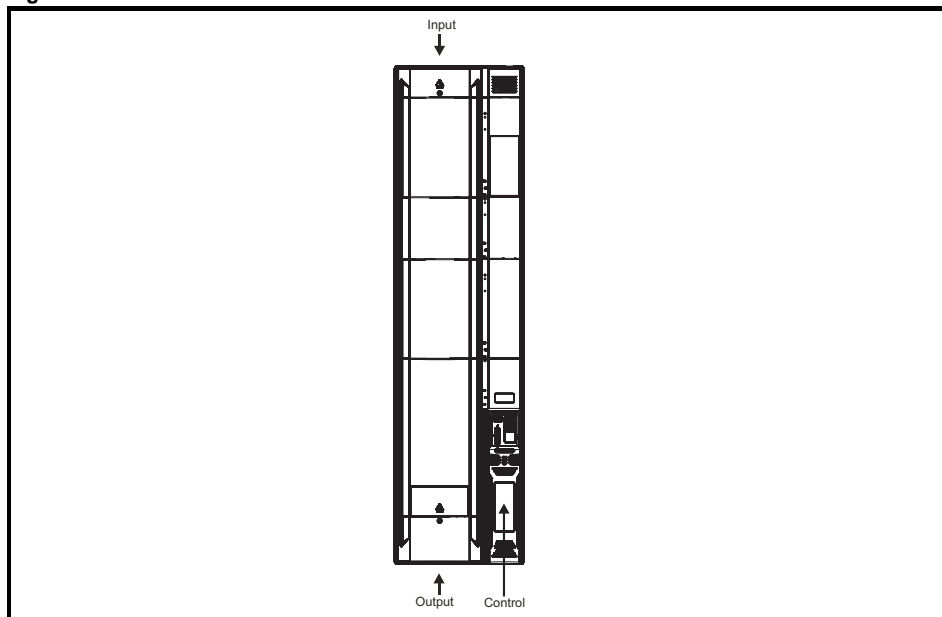

**Figure 3-4 Removing the terminal covers**

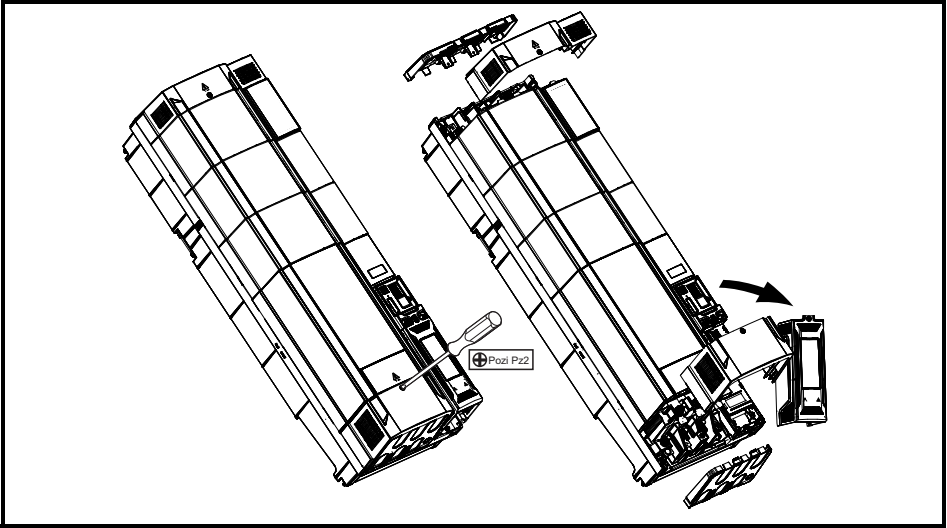

To remove a terminal cover, undo the screw and lift the terminal cover off as shown.

When replacing the terminal covers the screws should be tightened with a maximum torque of 1 N m (0.7 lb ft).

### **3.3.2 Removing the finger-guard and DC terminal cover break-outs**

**Figure 3-5 Removing the finger-guard break-outs**

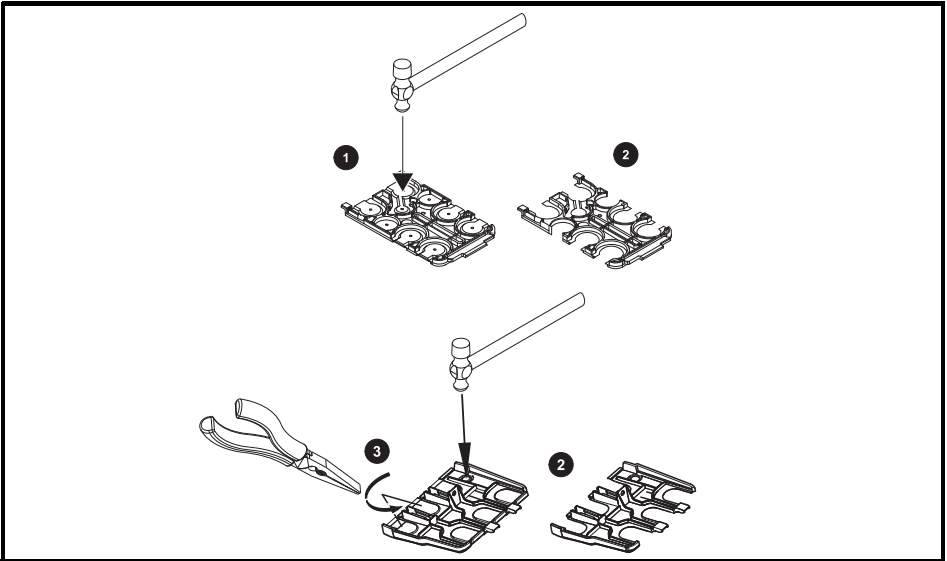

Place the finger-guard on a flat solid surface and hit relevant break-outs with hammer as shown (1). Pliers can be used to remove the breakouts, grasp the relevant break-out with pliers and twist it as shown (3). Continue until all the required break-outs have been removed (2). Remove any flash / sharp edges once the break-outs have been removed.



The grommets must be installed to ensure ingress protection to IP20 and to avoid the risk of fire in the event of a major internal failure.

A grommet kit is available for size 11 power terminal finger guards.

**Table 3-1 Grommet kit for power terminal finger guards**

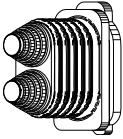
Drive size	Quantity of kits	Part number	Picture
Size 11 - Kit of 8 x double entry grommets	2	3470-0107	

### 3.4 Dimensions and mounting methods

The Unidrive M/HS Frame 11E can be either surface or through-panel mounted using the appropriate brackets. Surface mounting is where the drive is simply secured to the enclosure wall/backplate.

Through-panel mounting is where the drive is secured with the heatsink protruding through the enclosure panel to the external environment. This has the effect of reducing the temperature within the enclosure.

The following drawings show the dimensions of the drive and mounting holes for each method to allow a back plate to be prepared.



If the drive has been used at high load levels for a period of time, the heatsink can reach temperatures in excess of 70 °C (158 °F). Human contact with the heatsink should be prevented.

### 3.4.1 Drive dimensions

Figure 3-6 Drive dimensions

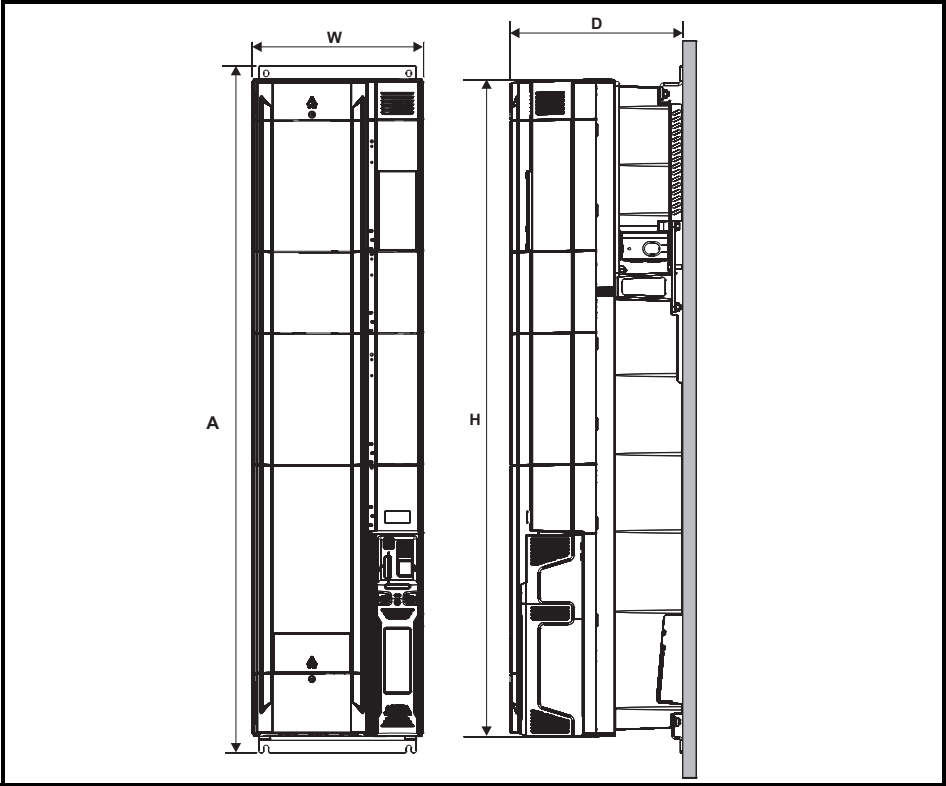

Size	H		W		D		A	
	mm	in	mm	in	mm	in	mm	in
11E	1190	46.9	310	12.2	312	12.28	1242	48.9



### 3.4.2 Surface mounting

Figure 3-7 Surface mounting dimensions

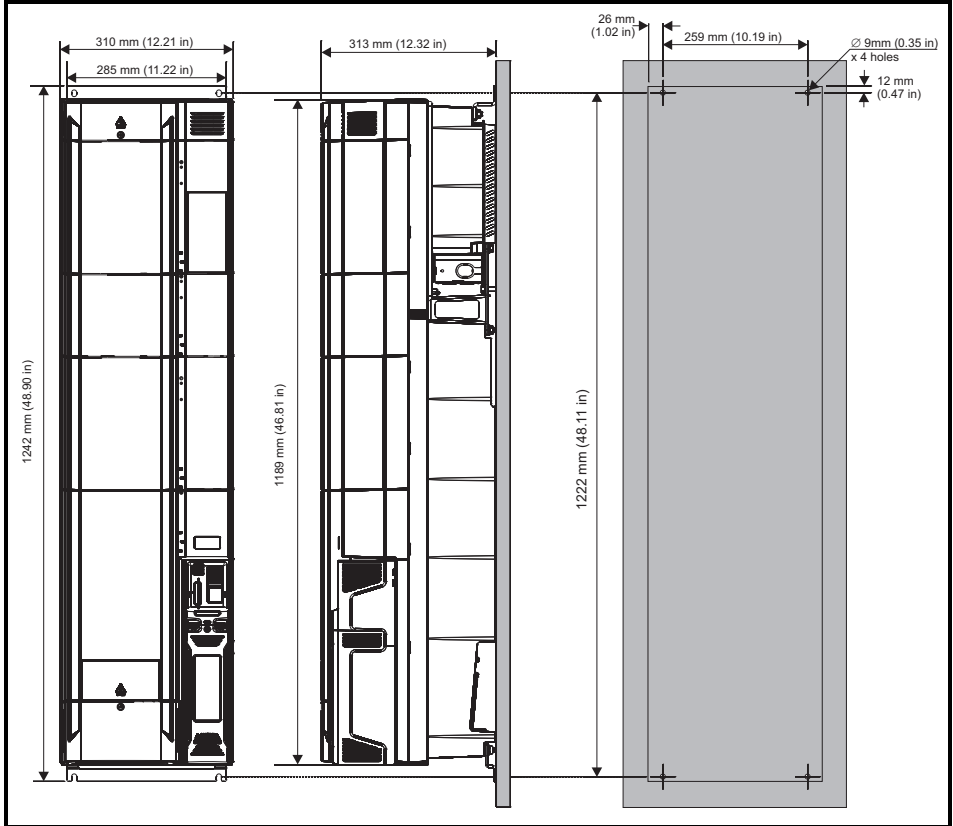

Safety information

Product information

Mechanical installation

Electrical installation

Technical data

UL listing information

### 3.4.3 Through-panel mounting

The Through-panel mounting kit is not supplied with the drive and can be purchased separately, using the part number shown below:

**Table 3-2 Through panel mounting kit**



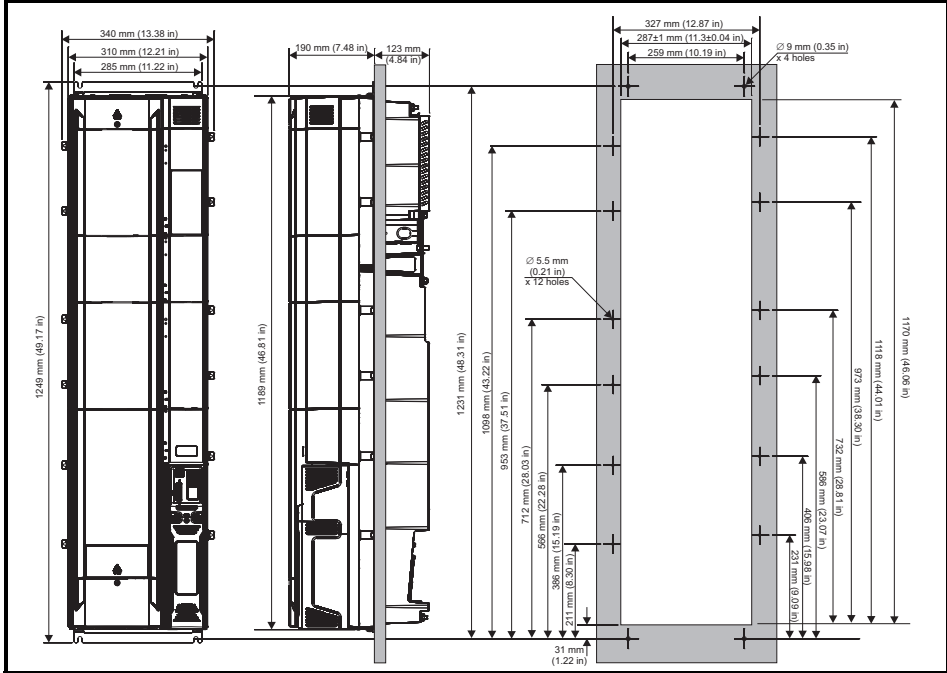

Part number	Description
3470-0126	Size 11E through panel mounting kit

**Figure 3-8 Through-panel mounting dimensions**

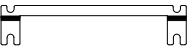

### 3.5 Mounting brackets

**Table 3-3 Mounting brackets**

Frame size	Surface mounting kit (supplied with drive)	Qty	Optional through-panel mounting kit	Qty
11E	 Hole size: 9 mm (0.35 in)	x 2*	 Hole size: 5.5 mm (0.22 in)	x 12
	 Hole size: 9 mm (0.35 in)	x 1		x 1

\* Surface mounting brackets are also used when through-panel mounting

### 3.6 Enclosure for standard drives

Please observe the clearances in the diagram below taking into account any appropriate notes for other devices / auxiliary equipment when planning the installation.

**Figure 3-9 Enclosure layout**

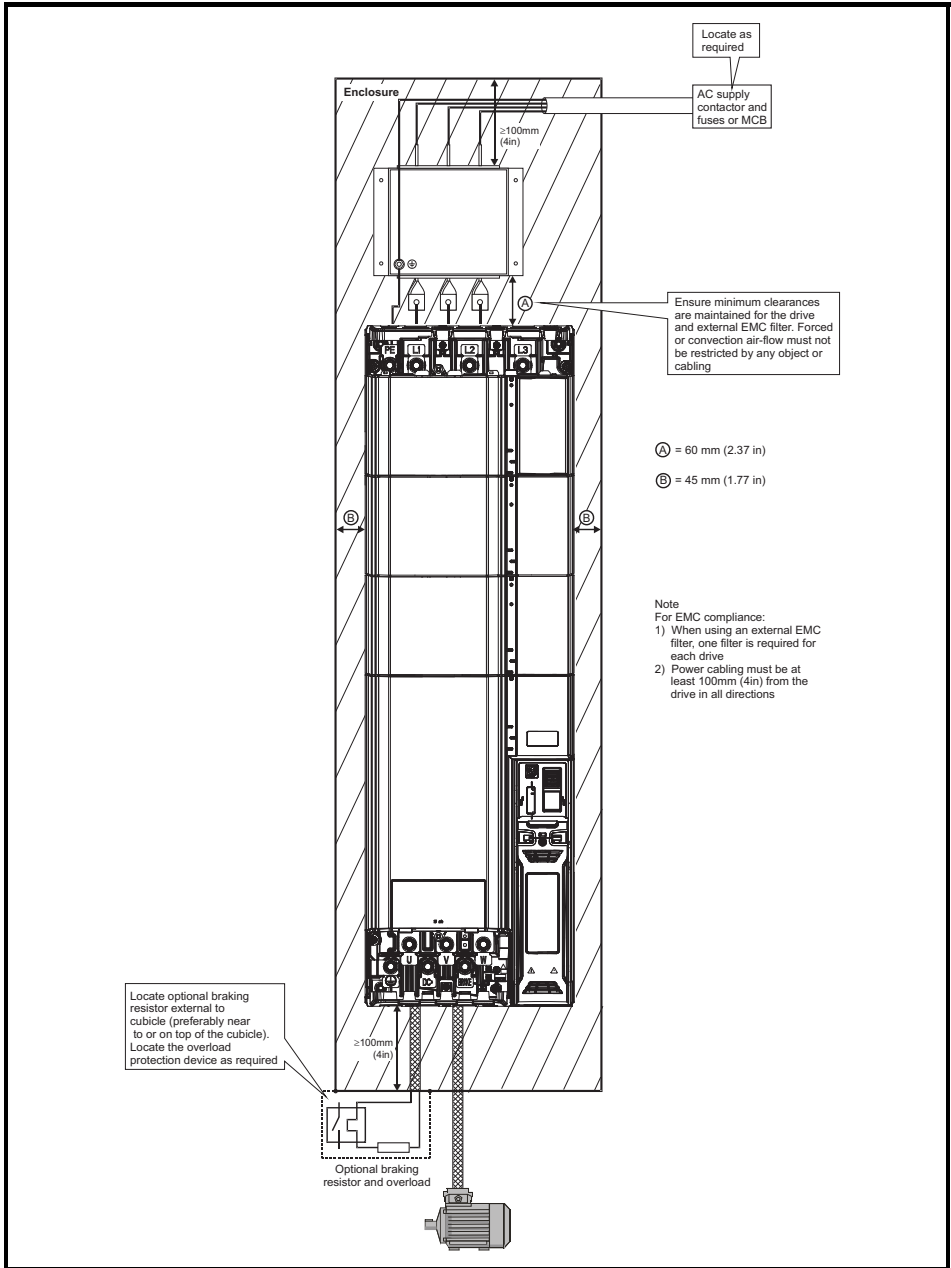

### 3.6.1 Enclosure sizing

1. Add the dissipation figures from section 5.1.3 *Power dissipation* on page 77 for each drive that is to be installed in the enclosure.
2. If an external EMC filter is to be used with each drive, add the dissipation figures from section 5.2.2 *EMC filter ratings* on page 90 for each external EMC filter that is to be installed in the enclosure.
3. If the braking resistor is to be mounted inside the enclosure, add the average power figures from for each braking resistor that is to be installed in the enclosure.
4. Calculate the total heat dissipation (in Watts) of any other equipment to be installed in the enclosure.
5. Add the heat dissipation figures obtained above. This gives a figure in Watts for the total heat that will be dissipated inside the enclosure.

#### Calculating the size of a sealed enclosure

The enclosure transfers internally generated heat into the surrounding air by natural convection (or external forced air flow); the greater the surface area of the enclosure walls, the better is the dissipation capability. Only the surfaces of the enclosure that are unobstructed (not in contact with a wall or floor) can dissipate heat.

Calculate the minimum required unobstructed surface area  $A_e$  for the enclosure from:

$$A_e = \frac{P}{k(T_{int} - T_{ext})}$$

Where:

$A_e$	Unobstructed surface area in $m^2$ ( $1 m^2 = 10.9 ft^2$ )
$T_{ext}$	Maximum expected temperature in $^{\circ}C$ <i>outside</i> the enclosure
$T_{int}$	Maximum permissible temperature in $^{\circ}C$ <i>inside</i> the enclosure
$P$	Power in Watts dissipated by <i>all</i> heat sources in the enclosure
$k$	Heat transmission coefficient of the enclosure material in $W/m^2/^{\circ}C$

#### Example

To calculate the size of an enclosure for the following:

- Two drives operating at the Normal Duty rating
- External EMC filter for each drive
- Braking resistors are to be mounted outside the enclosure
- Maximum ambient temperature inside the enclosure:  $40^{\circ}C$
- Maximum ambient temperature outside the enclosure:  $30^{\circ}C$

For example, if the power dissipation from each drive is 187 W and the power dissipation from each external EMC filter is 9.2 W.

Total dissipation:  $2 \times (187 + 9.2) = 392.4$  W

**NOTE** Power dissipation for the drives and the external EMC filters can be obtained from Chapter 5 *Technical data* on page 74.

The enclosure is to be made from painted 2 mm (0.079 in) sheet steel having a heat transmission coefficient of  $5.5 W/m^2/^{\circ}C$ . Only the top, front, and two sides of the enclosure are free to dissipate heat.

The value of  $5.5 W/m^2/^{\circ}C$  can generally be used with a sheet steel enclosure (exact values can be obtained by the supplier of the material). If in any doubt, allow for a greater margin in the temperature rise.

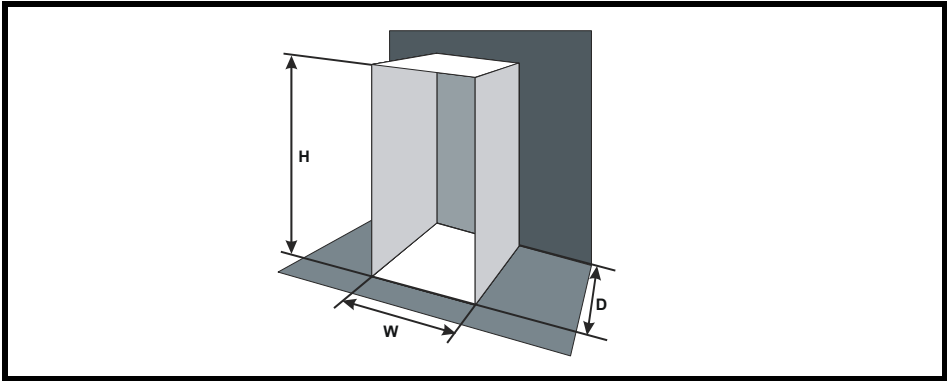
**Figure 3-10 Enclosure having front, sides and top panels free to dissipate heat**

Insert the following values:

$T_{\text{int}}$	40 °C
$T_{\text{ext}}$	30 °C
$k$	5.5
$P$	392.4 W

The minimum required heat conducting area is then:

$$A_e = \frac{392.4}{5.5(40 - 30)}$$

$$= 7.135 \text{ m}^2 (77.8 \text{ ft}^2) \quad (1 \text{ m}^2 = 10.9 \text{ ft}^2)$$

Estimate two of the enclosure dimensions - the height (H) and depth (D), for instance. Calculate the width (W) from:

$$W = \frac{A_e - 2HD}{H + D}$$

Inserting  $H = 2\text{ m}$  and  $D = 0.6\text{ m}$ , obtain the minimum width:

$$W = \frac{7.135 - (2 \times 2 \times 0.6)}{2 + 0.6}$$

$$= 1.821 \text{ m (71.7 in)}$$

If the enclosure is too large for the space available, it can be made smaller only by attending to one or all of the following:

- Using a lower PWM switching frequency to reduce the dissipation in the drives
- Reducing the ambient temperature outside the enclosure, and/or applying forced-air cooling to the outside of the enclosure
- Reducing the number of drives in the enclosure
- Removing other heat-generating equipment

#### Calculating the air-flow in a ventilated enclosure

The dimensions of the enclosure are required only for accommodating the equipment. The equipment is cooled by the forced air flow.

Calculate the minimum required volume of ventilating air from:

$$V = \frac{3kP}{T_{\text{int}} - T_{\text{ext}}}$$

Where:

<b>V</b>	Air-flow in m <sup>3</sup> per hour (1 m <sup>3</sup> /hr = 0.59 ft <sup>3</sup> /min)
<b>T<sub>ext</sub></b>	Maximum expected temperature in °C <i>outside</i> the enclosure
<b>T<sub>int</sub></b>	Maximum permissible temperature in °C <i>inside</i> the enclosure
<b>P</b>	Power in Watts dissipated by <i>all</i> heat sources in the enclosure
<b>k</b>	Ratio of $\frac{P_o}{P_i}$

Where:

- P<sub>0</sub>** is the air pressure at sea level
- P<sub>1</sub>** is the air pressure at the installation

Typically use a factor of 1.2 to 1.3, to allow also for pressure-drops in dirty air-filters.

### Example

To calculate the size of an enclosure for the following:

- Three drives operating at the Normal Duty rating
- External EMC filter for each drive
- Braking resistors are to be mounted outside the enclosure
- Maximum ambient temperature inside the enclosure: 40 °C
- Maximum ambient temperature outside the enclosure: 30 °C

For example, dissipation of each drive: 101 W and dissipation of each external EMC filter: 6.9 W (max).

Total dissipation: 3 x (101 + 6.9) = 323.7 W

Insert the following values:

<b>T<sub>int</sub></b>	40 °C
<b>T<sub>ext</sub></b>	30 °C
<b>k</b>	1.3
<b>P</b>	323.7 W

Then:

$$V = \frac{3 \times 1.3 \times 323.7}{40 - 30}$$
$$= 126.2 \text{ m}^3/\text{hr} \text{ (74.5 ft}^3/\text{min)} \quad (1 \text{ m}^3/\text{hr} = 0.59 \text{ ft}^3/\text{min)}$$

### 3.7 Enclosure design and drive ambient temperature

Drive derating is required for operation in high ambient temperatures

Totally enclosing or through panel mounting the drive in either a sealed cabinet (no airflow) or in a well ventilated cabinet makes a significant difference on drive cooling.

The chosen method affects the ambient temperature value ( $T_{rate}$ ) which should be used for any necessary derating to ensure sufficient cooling for the whole of the drive.

The ambient temperature for the four different combinations is defined below:

1. Totally enclosed with no air flow (<2 m/s) over the drive  
 $T_{rate} = T_{int} + 5^{\circ} C$
2. Totally enclosed with air flow (>2 m/s) over the drive  
 $T_{rate} = T_{int}$
3. Through panel mounted with no airflow (<2 m/s) over the drive  
 $T_{rate} = \text{the greater of } T_{ext} + 5^{\circ}C, \text{ or } T_{int}$
4. Through panel mounted with air flow (>2 m/s) over the drive  
 $T_{rate} = \text{the greater of } T_{ext} \text{ or } T_{int}$

Where:

$T_{ext}$  = Temperature outside the cabinet

$T_{int}$  = Temperature inside the cabinet

$T_{rate}$  = Temperature used to select current rating

### 3.8 Heatsink fan operation

The Unidrive M / Unidrive HS size 11E are ventilated by a heatsink mounted fan and an auxiliary fan to ventilate the drive box. The fan housing forms a baffle plate, channelling the air through the heatsink chamber. Thus, regardless of mounting method (surface mounting or through-panel mounting), the installation of additional baffle plates is not required.

Ensure the minimum clearances around the drive are maintained to allow air to flow freely.

The heatsink fan on Unidrive M / Unidrive HS size 11E is a variable speed device. The drive controls the speed at which the fan runs based on the temperature of the heatsink and the drive's thermal model system. The drive is also installed with a variable speed fan to ventilate the capacitor bank.

### 3.9 Enclosing standard drive for high environmental protection

The standard drive is rated to IP20 pollution degree 2 (dry, non-conductive contamination only) (NEMA 1). However, it is possible to configure the drive to achieve a higher IP rating at the rear of the heatsink when through-panel mounted.

This allows the front of the drive, along with various switchgear, to be housed in an IP55 (NEMA 12) enclosure with the heatsink protruding through the panel to the external environment. Thus, the majority of the heat generated by the drive is dissipated outside the enclosure maintaining a reduced temperature inside the enclosure. This also relies on a good seal being made between the heatsink and the rear of the enclosure using the gasket provided in the through panel mounting kit.

**Figure 3-11 Example of high IP through-panel layout**

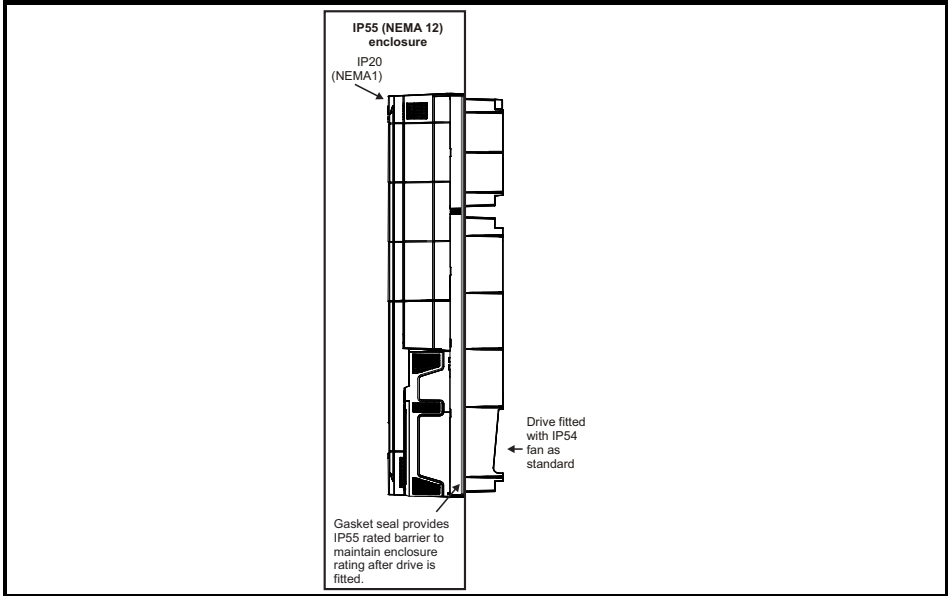

The main gasket should be installed as shown in Figure 3-11. Any screws / bolts that are used for mounting should be installed with M8 flat nylon washers to maintain a seal around the screw hole.

See Figure 3-12 on page 33, sealing clamps are supplied in the through panel mounting kit to aid compression of the gasket.

**NOTE**

The heatsink fans have conformal coated PCBs and have sealant at cable entry points. Dripping, splashing or sprayed water can impede the operation of the fan, therefore if the environment is such that the fan may be subjected to more than occasional dripping or sprayed water while operational, then suitable drip protection covers should be employed.



**Figure 3-12 View showing sealing clamps provided in through hole mounting kit**

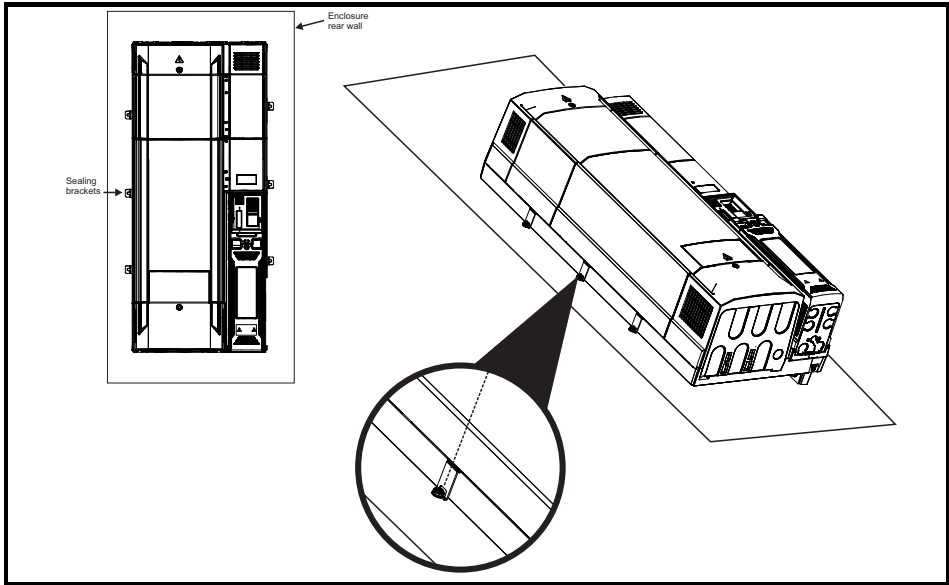

**NOTE** For detailed information regarding IP55 (NEMA 12) Through Panel Mounting see Figure 3-8 *Through-panel mounting dimensions* on page 26.

**NOTE** When designing an IP55 (NEMA 12) enclosure (Figure 3-11 *Example of high IP through-panel layout* on page 32), consideration should be given to the dissipation from the front of the drive.

**Table 3-4 Power losses from the front of the drive when through-panel mounted**

Frame size	Power loss
All sizes	≤ 480 W

### 3.10 External EMC filter

The external EMC filters are designed to be mounted above the drive as shown in Figure 3-13.

**Figure 3-13 Mounting of the EMC filter**

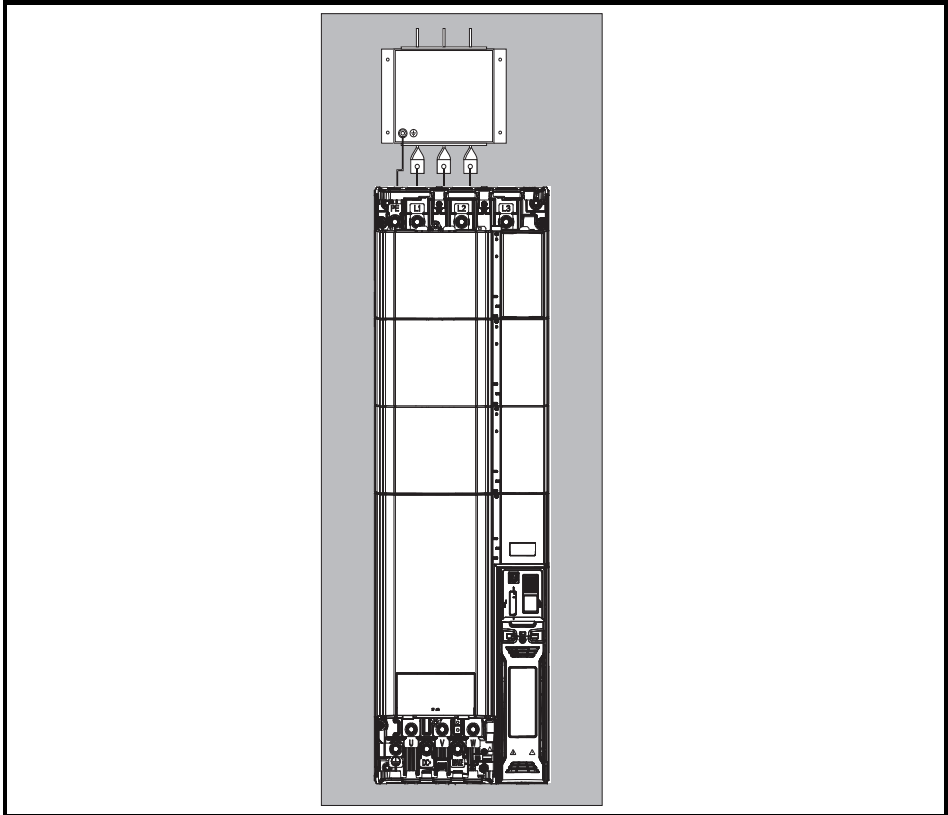

#### 3.10.1 Optional external EMC filters

**Table 3-5 EMC filter cross reference**

Model	CT part number
<b>400 V</b>	
11403770	4200-0400
11404170	4200-0400
11404640	4200-0400
<b>575 V</b>	
11502000	4200-0690
11502540	4200-0690
11502850	4200-0690
<b>690 V</b>	
11602100	4200-0690
11602380	4200-0690
11602630	4200-0690

### 3.10.2 EMC filter ratings

Table 3-6 Optional external EMC filter details

CT part number	Maximum continuous current		Voltage rating		IP rating	Power dissipation at rated current		Ground leakage		Discharge resistors
	@ 40 °C (104 °F)	@ 50 °C (122 °F)	IEC	UL		@ 40 °C (104 °F)	@ 50 °C (122 °F)	Balanced supply phase-to-phase and phase-to-ground	Worst case	
	A	A	V	V		W	W	mA	mA	
4200-0400	685	551	480	480	00	44	38.5	60.7	275	1.68
4200-0690	403	368	690	N/A	00	28	24.5	25	583	2.72

### 3.10.3 EMC filter dimensions

Figure 3-14 External EMC filter

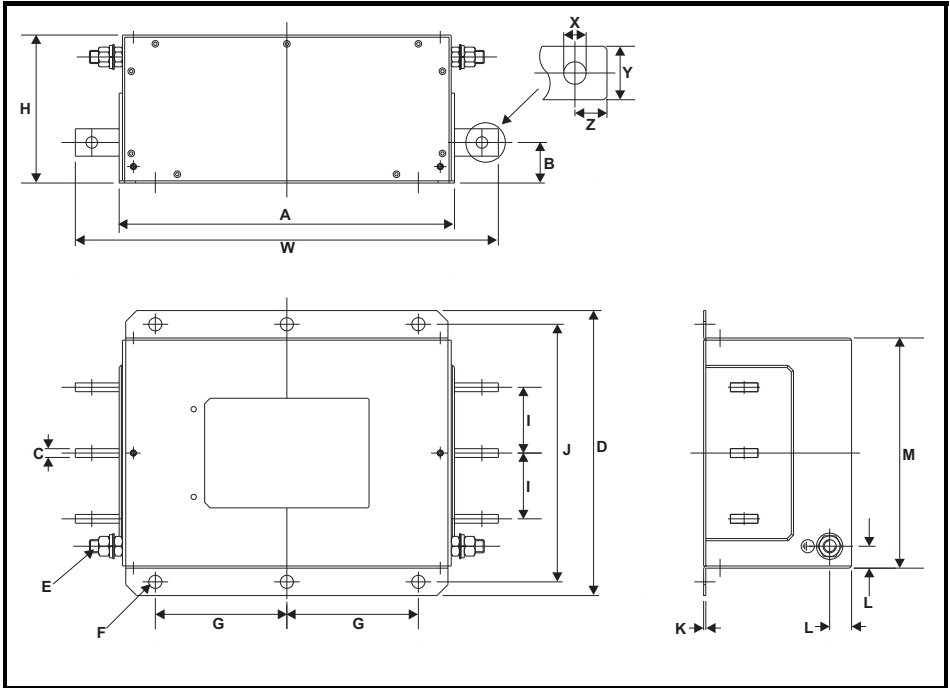

Table 3-7 External EMC filter dimensions

CT part number	A	B	C	D	E	F	G	H	I	J	K
4200-0400	306 mm (12.05 in)	37 mm (1.46 in)	8 mm (0.32 in)	260 mm (10.2 in)	M12	12 mm (0.47 in)	120 mm (4.72 in)	135 mm (5.32 in)	60 mm (2.36 in)	235 mm (9.25 in)	2 mm (0.08 in)
4200-0690											
CT part number	L	M	X	Y	Z	W					
4200-0400	20 mm (0.79 in)	210 mm (8.27 in)	10.5 mm (0.41 in)	25 mm (0.98 in)	15 mm (0.59 in)	386 mm (15.20 in)					
4200-0690											

### 3.10.4 EMC filter torque settings

Table 3-8 Optional external EMC Filter terminal data

CT part number	Power connections		Ground connections	
	Bar hole diameter	Max torque	Ground stud size	Max torque
4200-0400	10.5 mm	30 N m (22.1 lb ft)	M12	25 Nm
4200-0690				

### 3.11 Terminal size and torque settings

Table 3-9 Drive control and relay terminal data

Model	Connection type	Torque setting
All	Plug-in terminal block	0.5 N m (0.4 lb ft)

Table 3-10 Drive power terminal data

AC terminals	DC and braking	Ground terminal
M10 Nut (17 mm AF)	M10 Nut (17 mm AF)	M10 Nut (17 mm AF)
15.0 N m (11.1 lb ft)	15.0 N m (11.1 lb ft)	15 N m (11.1 lb ft)

### 3.12 Input line reactors

Table 3-11 Model and Line reactor part number

Model	CT part number	Model number
<b>400 V</b>		
11403770	4401-0259	INL 403
	4401-0274	INL 403L*
11404170	4401-0259	INL 403
11404640	4401-0259	INL 403
<b>575 V</b>		
11502000	4401-0261	INL 603
11502540	4401-0261	INL 603
11502850	4401-0261	INL 603
<b>690 V</b>		
11602100	4401-0261	INL 603
11602380	4401-0261	INL 603
11602630	4401-0261	INL 603

\* May represent a more economic solution when operating within heavy duty ratings.

Figure 3-15 Input line reactor dimensions

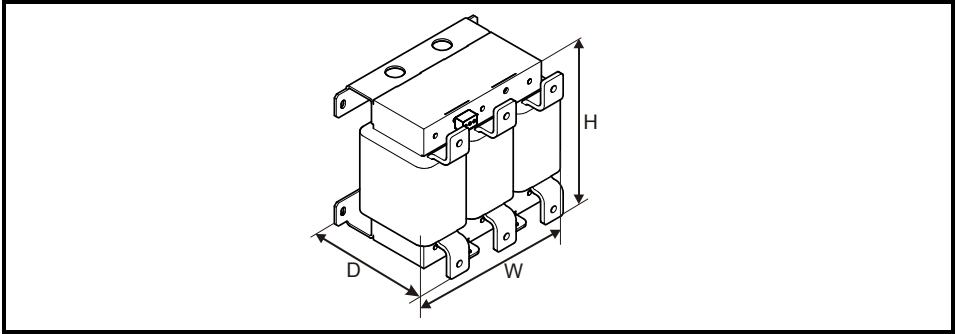

Table 3-12 Input line reactor ratings

Model	Model number	Current	Inductance	Overall width (W)	Overall depth (D)	Overall height (H)	Weight	Max ambient temp*	Max ambient temp**	Maximum losses
		A	$\mu$ H	mm	mm	mm				kg
11403770	INL 403	557	30	300	216	264	57	40	50	330
	INL 403L	420	30				57			289
11404170	INL 403	557	30				57			330
11404640	INL 403	557	30				57			330
11502000	INL 603	331	93				58			320
11502540	INL 603	331	93				58			320
11502850	INL 603	331	93				58			320
11602100	INL 603	331	93				58			320
11602380	INL 603	331	93				58			320
11602630	INL 603	331	93				58			320

\* With natural cooling.

\*\* With forced cooling = 1 m/s.

### 3.13 Routine maintenance

The drive should be installed in a cool, clean, well ventilated location. Contact of moisture and dust with the drive should be prevented.

Regular checks of the following should be carried out to ensure drive / installation reliability are maximized:

<b>Environment</b>	
Ambient temperature	Ensure the enclosure temperature remains at or below maximum specified
Dust	Ensure the drive remains dust free – check that the heatsink and drive fan are not gathering dust. The lifetime of the fan is reduced in dusty environments.
Moisture	Ensure the drive enclosure shows no signs of condensation
<b>Enclosure</b>	
Enclosure door filters	Ensure filters are not blocked and that air is free to flow
<b>Electrical</b>	
Screw connections	Ensure all screw terminals remain tight
Crimp terminals	Ensure all crimp terminals remains tight – check for any discoloration which could indicate overheating
Cables	Check all cables for signs of damage

### 3.13.1 Heatsink fan replacement

Figure 3-13 Heatsink fan replacement

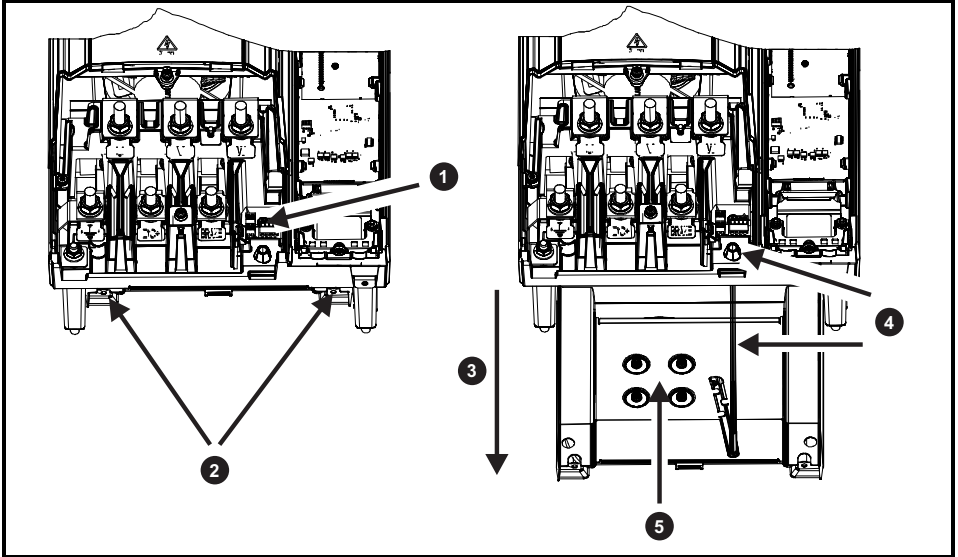

#### Heatsink fan removal procedure

- 1) Using a flat screwdriver remove the fan wires from the fan connector (making a note of the order).
  - 2) Using a T20 Torque driver remove the two screws that retain the heatsink fan housing
  - 3) Withdraw the heatsink fan housing from the drive in the direction shown
  - 4) Pull the fan cable through the fan cable gland
  - 5) Using a T20 Torque driver remove the four screws that retain the fan in the housing
- After the fan has been replaced, reverse the above steps to refit.

Table 3.16 Heatsink fan part number

Drive model	Heatsink fan part number
Size 11	3251-1750

### 3.13.2 Auxiliary (capacitor bank) fan replacement

Figure 3-17 Auxiliary (capacitor bank) fan replacement

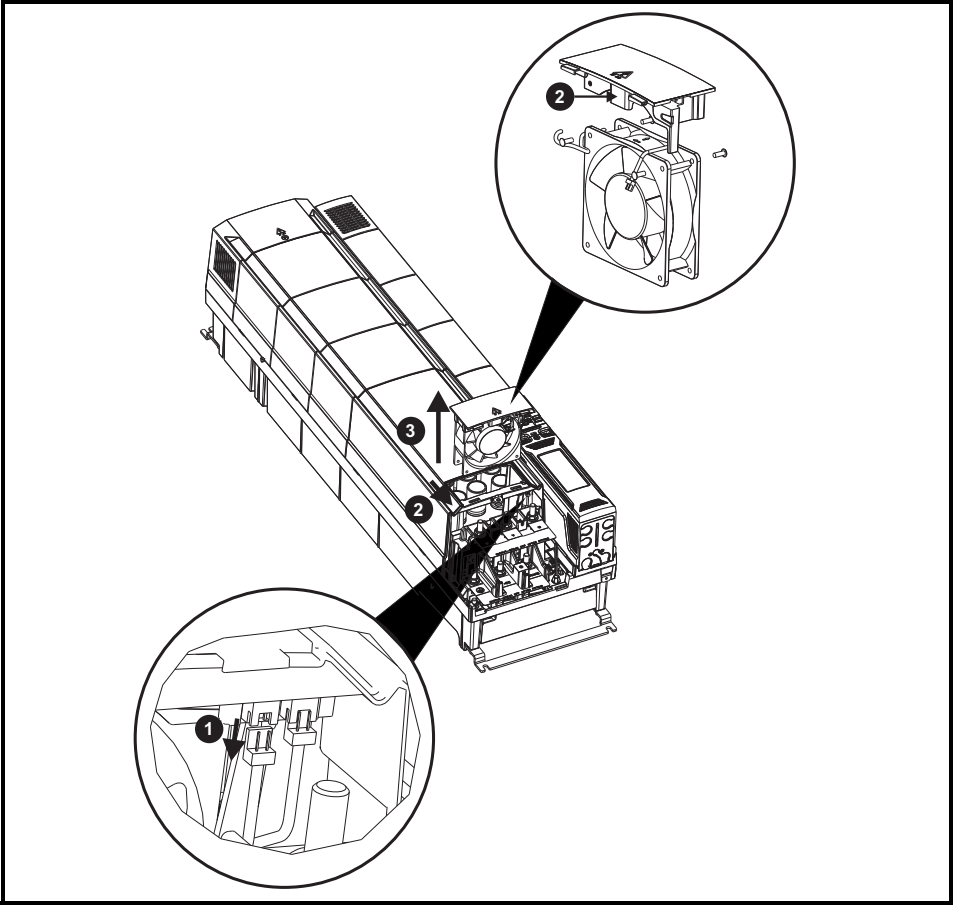

#### Auxiliary fan removal procedure

- 1) Disconnect the fan wiring connector as shown.
- 2) Slide the fan housing in the direction shown using the tongue shown in the enlarged diagram of the fan.
- 3) Withdraw the fan housing from the drive.

After the fan has been replaced, reverse the above steps to refit.

Table 3-14 Auxillary (capacitor bank) fan part numbers

Drive model	Auxiliary (capacitor bank) fan part number
Size 11(575V and 690V)	3251-0042
Size 11 (400V)	3251-1202



### 3.13.3 Size 11E rectifier fan replacement

Figure 3-18 Size 11E rectifier fan replacement

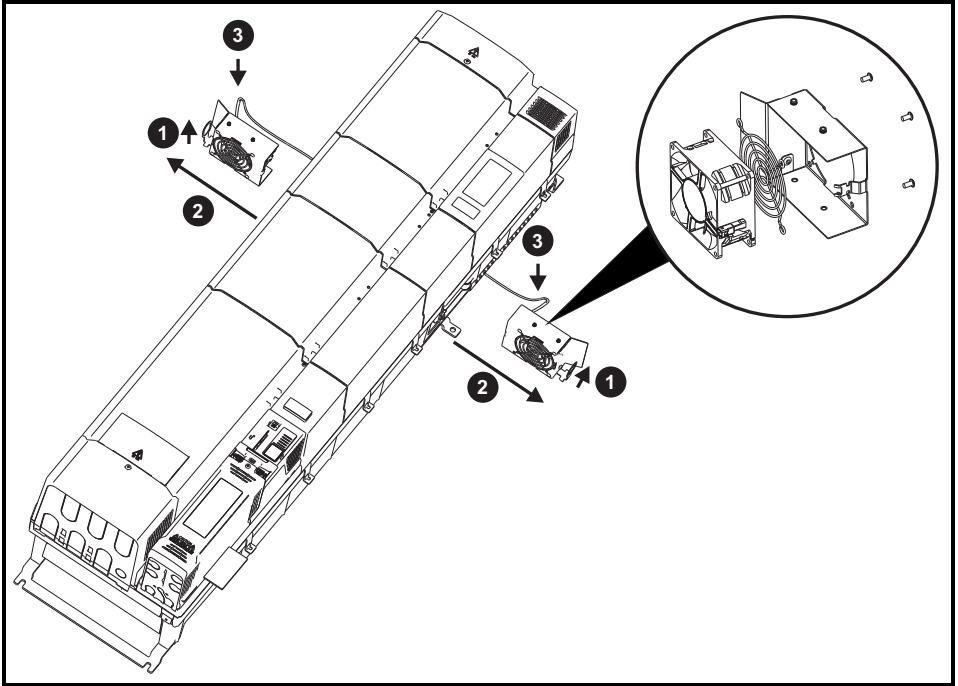

#### Size 11 rectifier fan removal procedure

- 1) Lift the ring eyes provided (one on each side of the drive).
- 2) Pull the fan housing in the direction shown.
- 3) Disconnect the fan wiring connector at the location highlighted.

After the fans have been replaced, reverse the above steps to refit the fan housing in the rectifier (making sure the fan housing aligns correctly in the slots top and bottom).

Table 3-15 Rectifier fan part number

Drive model	Rectifier fan part number
Size 11E rectifier	3251-0030

---

## 4 Electrical installation

---



WARNING

### Electric shock risk

The voltages present in the following locations can cause severe electric shock and may be lethal:

- AC supply cables and connections
- DC and brake cables, and connections
- Output cables and connections

Many internal parts of the drive, and external option units

Unless otherwise indicated, control terminals are single insulated and must not be touched.



WARNING

### Isolation device

The AC and / or DC power supply must be disconnected from the drive using an approved isolation device before any cover is removed from the drive or before any servicing work is performed.



WARNING

### STOP function

The STOP function does not remove dangerous voltages from the drive, the motor or any external option units.



WARNING

### Safe Torque Off function

The Safe Torque Off function does not remove dangerous voltages from the drive, the motor or any external option units.



WARNING

### Stored charge

The drive contains capacitors that remain charged to a potentially lethal voltage after the AC and / or DC power supply has been disconnected. If the drive has been energized, the AC and / or DC power supply must be isolated at least ten minutes before work may continue. Normally, the capacitors are discharged by an internal resistor. Under certain, unusual fault conditions, it is possible that the capacitors may fail to discharge, or be prevented from being discharged by a voltage applied to the output terminals. If the drive has failed in a manner that causes the display to go blank immediately, it is possible the capacitors will not be discharged. In this case, consult Nidec Industrial Automation or their authorized distributor.



WARNING

### Equipment supplied by plug and socket

Special attention must be given if the drive is installed in equipment which is connected to the AC supply by a plug and socket. The AC supply terminals of the drive are connected to the internal capacitors through rectifier diodes which are not intended to give safety isolation. If the plug terminals can be touched when the plug is disconnected from the socket, a means of automatically isolating the plug from the drive must be used (e.g. a latching relay).



WARNING

### Permanent magnet motors

Permanent magnet motors generate electrical power if they are rotated, even when the supply to the drive is disconnected. If that happens then the drive will become energized through its motor terminals. If the motor load is capable of rotating the motor when the supply is disconnected, then the motor must be isolated from the drive before gaining access to any live parts.

# 4.1 Power connections

Figure 4-1 Power connections

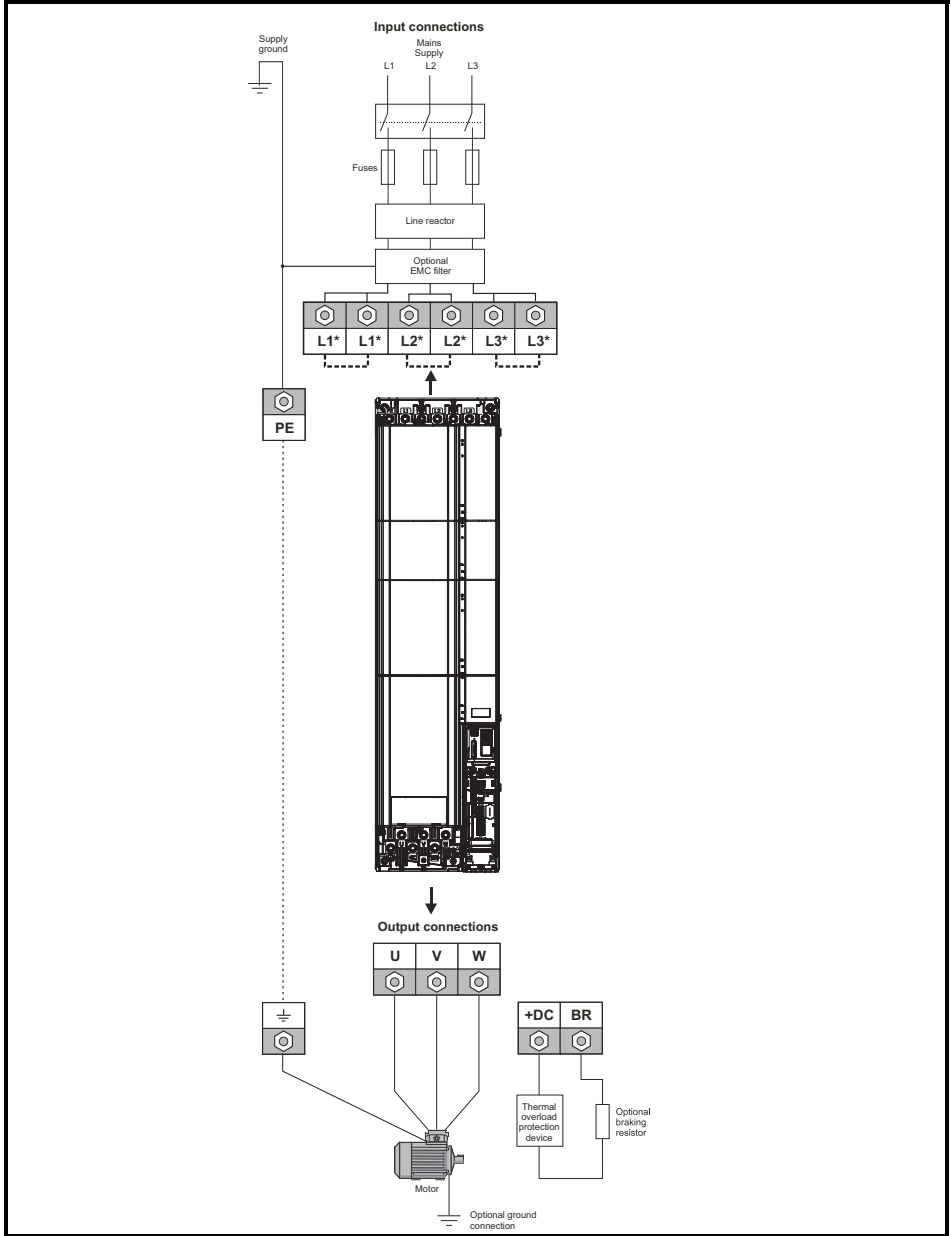

\* Common AC supply connections are internally linked.

## 4.2 Ground connections



### Electrochemical corrosion of grounding terminals

Ensure that grounding terminals are protected against corrosion i.e. as could be caused by condensation.



The ground loop impedance must conform to the requirements of local safety regulations. The drive must be grounded by a connection capable of carrying the prospective fault current until the protective device (fuse, etc.) disconnects the AC supply. The ground connections must be inspected and tested at appropriate intervals.

The drive must be connected to the system ground of the AC supply. The ground wiring must conform to local regulations and codes of practice.

#### NOTE

For further information on ground cable sizes, refer to Table 2-4 *Protective ground cable ratings* on page 15.

The supply and motor ground connections are made using the M10 studs located by the supply and motor connection terminals. Refer to Figure 4-2.

The supply ground and motor ground connections to the drive are connected internally by a copper conductor with a cross-sectional area given below:

Frame size	Internal connection cross sectional area mm <sup>2</sup>
11E	42

Figure 4-2 Unidrive M/Unidrive HS size 11E ground connections

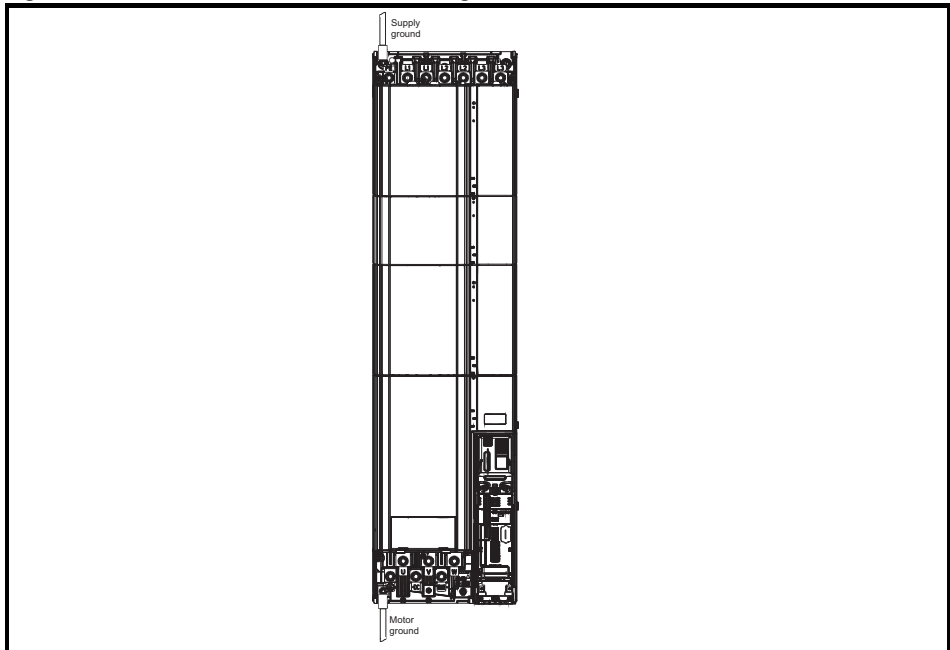

## 4.3 AC Supply requirements

AC supply voltage:

400 V drive: 380 V to 480 V  $\pm 10$  %

575 V drive: 500 V to 575 V  $\pm 10$  %

690 V drive: 500 V to 690 V  $\pm 10$  %

Number of phases: 3

Maximum supply imbalance: 2 % negative phase sequence (equivalent to 3 % voltage imbalance between phases).

Frequency range: 45 to 66 Hz

For UL compliance only, the maximum supply symmetrical fault current must be limited to 100 kA

**Table 4-1 Supply fault current used to calculate maximum input currents**

Model	Symmetrical fault level (kA)
All	100

### 4.3.1 Supply types

All drives are suitable for use on any supply type i.e TN-S, TN-C-S, TT and IT.

Supplies with voltage up to 600 V may have grounding at any potential, i.e. neutral, centre or corner ("grounded delta")

Supplies with voltage above 600 V may not have corner grounding

Drives are suitable for use on supplies of installation category III and lower, according to IEC 60664-1. This means they may be connected permanently to the supply at its origin in a building, but for outdoor installation additional over-voltage suppression (transient voltage surge suppression) must be provided to reduce category IV to category III.



Operation with IT (ungrounded) supplies:

Special attention is required when using internal or external EMC filters with ungrounded supplies, because in the event of a ground (earth) fault in the motor circuit the drive may not trip and the filter could be over-stressed. In this case, additional independent motor ground fault protection must be provided, refer to Table 4-2. For details of ground fault protection contact the supplier of the drive.

A ground fault in the supply has no effect in any case. If the motor must continue to run with a ground fault in its own circuit then an input isolating transformer must be provided and if an EMC filter is required it must be located in the primary circuit.

Unusual hazards can occur on ungrounded supplies with more than one source, for example on ships. Contact the supplier of the drive for more information.

**Table 4-2 Behavior of the drive in the event of a ground (earth) fault with an IT supply**

Drive size	Internal filter only*	External filter (with internal)
(All sizes)	May not trip – precautions required: <ul style="list-style-type: none"> <li>• Use ground leakage relay</li> </ul>	May not trip – precautions required: <ul style="list-style-type: none"> <li>• Do not use EMC filter</li> <li>• Use ground leakage relay</li> </ul>

\* Note that it is not possible to remove the internal EMC filter on size 11E.

## 4.4 Line reactors

Input line reactors reduce the risk of damage to the drive resulting from poor phase balance or severe disturbances on the supply network.

Where line reactors are to be used, reactance values of approximately 2 % are recommended. Higher values may be used if necessary, but may result in a loss of drive output (reduced torque at high speed) because of the voltage drop.

For all drive ratings, 2 % line reactors permit drives to be used with a supply unbalance of up to 3.5 % negative phase sequence (equivalent to 5 % voltage imbalance between phases).

Severe disturbances may be caused by the following factors, for example:

- Power factor correction equipment connected close to the drive.
- Large DC drives having no or inadequate line reactors connected to the supply.
- Across the line (DOL) started motor(s) connected to the supply such that when any of these motors are started, the voltage dip exceeds 20 %

Such disturbances may cause excessive peak currents to flow in the input power circuit of the drive. This may cause nuisance tripping, or in extreme cases, failure of the drive.

Drives of low power rating may also be susceptible to disturbance when connected to supplies with a high rated capacity.

Drive size 11E does not have internal input line reactor hence an external input line reactor must be used.

Each drive must have its own reactor(s). Three individual reactors or a single three-phase reactor should be used.

### Reactor current ratings

The current rating of the line reactors should be as follows:

Continuous current rating:

Not less than the continuous input current rating of the drive

Repetitive peak current rating:

Not less than twice the continuous input current rating of the drive

**Figure 4-3 Input line reactor/output sharing choke dimensions**

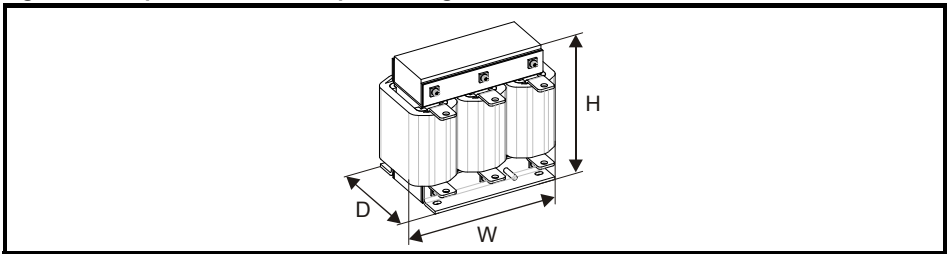

**Table 4-3 Input line reactor ratings**

Model	Model number	Current	Inductance	Overall width (W)	Overall depth (D)	Overall height (H)	Weight	Max ambient temp*	Max ambient temp**	Maximum losses
		A	μH	mm	mm	mm		°C	°C	W
11403770	INL 403L	420	30	300	216	264	57	40	50	289
	INL 403	557	30				57			330
11404170	INL 403	557	30				57			330
11404640	INL 403	557	30				57			330
11502000	INL 603	331	93				58			320
11502540	INL 603	331	93				58			320
11502850	INL 603	331	93				58			320
11602100	INL 603	331	93				58			320
11602380	INL 603	331	93				58			320
11602630	INL 603	331	93				58			320

\* With natural cooling.

\*\* With forced cooling = 1 m/s.

#### 4.4.1 Input inductor calculation

To calculate the inductance required (at Y %), use the following equation:

$$L = \frac{Y}{100} \times \frac{V}{\sqrt{3}} \times \frac{1}{2\pi f I}$$

Where:

I = drive rated input current (A)

L = inductance (H)

f = supply frequency (Hz)

V = voltage between lines

## 4.5 24 Vdc supply

The 24 Vdc supply connected to control terminals 1 & 2\* provides the following functions:

- It can be used to supplement the drive's own internal 24 V supply when multiple option modules are being used and the current drawn by these module is greater than the drive can supply.
- It can be used as a back-up power supply to keep the control circuits of the drive powered up when the line power supply is removed. This allows any fieldbus modules, application modules, encoders or serial communications to continue to operate.
- It can be used to commission the drive when the line power supply is not available, as the display operates correctly. However, the drive will be in the Under voltage trip state unless either line power supply or low voltage DC operation is enabled, therefore diagnostics may not be possible. (Power down save parameters are not saved when using the 24 V back-up power supply input).
- If the DC bus voltage is too low to run the main SMPS in the drive, then the 24 V supply can be used to supply all the low voltage power requirements of the drive. *Low Under Voltage Threshold Select* (06.067) must also be enabled for this to happen.

#### NOTE

On size 11, the power 24 Vdc supply (terminals 51, 52) must be connected to enable the 24 V dc supply to be used as a backup supply, when the line power supply is removed. If the power 24 Vdc supply is not connected none of the above mentioned functions can be used, "Waiting For Power System" will be displayed on the keypad and no drive operations are possible. The location of the

power 24 Vdc can be identified from Figure 4-4 *Location of the 24 Vdc power supply connection on size 11 on page 49*

**Table 4-4 24 Vdc supply connections**

Function	Terminal
Supplement the drive's internal supply	Terminal 1, 2*
Back-up supply for the control circuit	Terminal 1, 2* 51, 52

\* Terminal 9 on *Unidrive M702* and *HS72*

The working voltage range of the control 24 V power supply is as follows:

<b>1</b>	<b>0V common</b>
<b>2</b>	<b>+24 Vdc *</b>
Nominal operating voltage	24.0 Vdc
Minimum continuous operating voltage	19.2 V
Maximum continuous operating voltage	28.0 V
Minimum start up voltage	21.6 V
Maximum power supply requirement at 24 V	40 W
Recommended fuse	3 A, 50 Vdc

\* Terminal 9 on *Unidrive M702* and *HS72*

Minimum and maximum voltage values include ripple and noise. Ripple and noise values must not exceed 5 %.

The working range of the 24 V power supply is as follows:

<b>51</b>	<b>0V common</b>
<b>52</b>	<b>+24 Vdc</b>
<b>Size 11</b>	
Nominal operating voltage	24.0 Vdc
Minimum continuous operating voltage	19.2 Vdc
Maximum continuous operating voltage	30 Vdc (IEC), 26 Vdc (UL)
Minimum startup voltage	21.6 Vdc
Maximum power supply requirement	60 W
Recommended fuse	4 A @ 50 Vdc



**Figure 4-4** Location of the 24 Vdc power supply connection on size 11

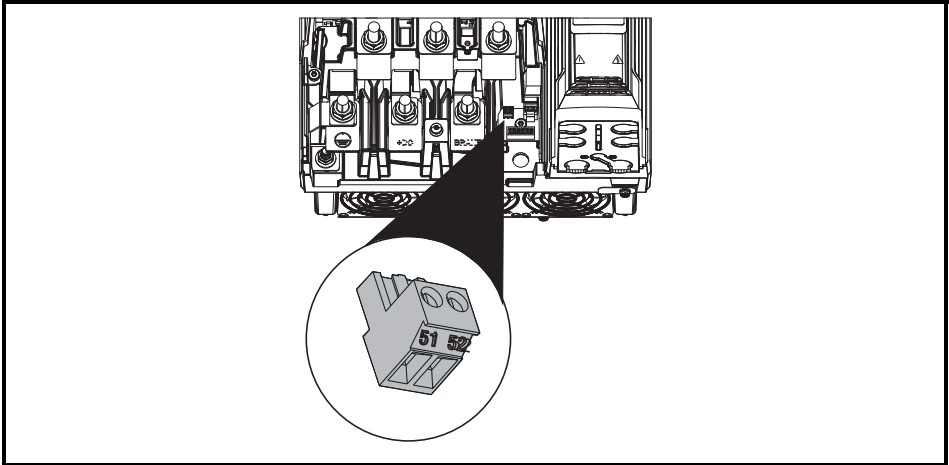

## 4.6 Low voltage operation

With the addition of a 24 Vdc power supply to supply the control circuits, the drive is able to operate from a low voltage DC supply with a range from 24 Vdc to the maximum DC volts. It is possible for the drive to go from operating on a normal line power supply voltage to operating on a much lower supply voltage without interruption.

Going from low voltage operation to normal mains operation requires the inrush current to be controlled. This may be provided externally. If not, the drive supply can be interrupted to utilise the normal soft starting method in the drive.

To fully exploit the new low voltage mode of operation, the under voltage trip level is now user programmable. For application data, contact the supplier of the drive.

The working voltage range of the low voltage DC power supply is as follows:

### Size 11

Minimum continuous operating voltage:	26 V
Minimum start up voltage:	32 V
Maximum over voltage trip threshold:	230 V drives: 415 V
	400 V drives: 830 V
	575 V drives: 990 V
	690 V drives: 1190 V

In low voltage mode only, a 24 V supply needs to be provided for the heatsink fan. The fan supply should be connected to terminal 61 and 62.

<b>61</b>	<b>0V common</b>
<b>62</b>	<b>+24 Vdc heatsink fan supply</b>
<b>Size 11</b>	
Nominal operating voltage	24.0 Vdc
Minimum continuous operating voltage	23.5 Vdc
Maximum continuous operating voltage	27 Vdc
Current consumption	Size 11 (all): 6A
Recommended power supply	24 V, 7 A
Recommended fuse	8A fast blow

**Figure 4-5 Location of the heatsink fan supply connector**

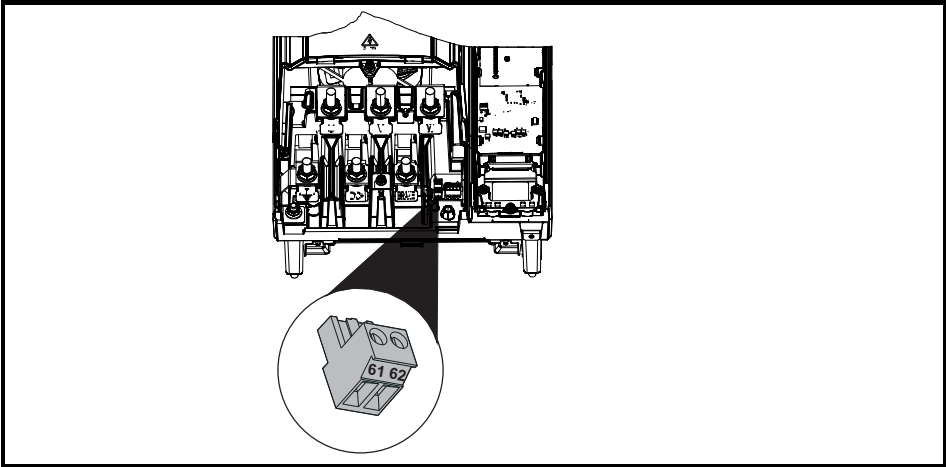

## 4.7 Heatsink fan supply

When operating on normal mains supply, the heatsink fan on all drive sizes is supplied internally by the drive. When operating in low voltage mode it is necessary to connect an external 24V supply to terminal 61 and 62 if heatsink fan operation is required. Please see section 4.6 *Low voltage operation* for more details.

## 4.8 Motor requirements

No. of phases: 3

Maximum voltage:

400 V drive: 480 V

575 V drive: 575 V

690 V drive: 690 V

## 4.9 Ratings

See section 2.4 *Ratings* on page 14.

### Maximum continuous input current

The values of maximum continuous input current are given to aid the selection of cables and fuses. These values are stated for the worst case condition with the unusual combination of stiff supply with high imbalance. The value stated for the maximum continuous input current would only be seen in one of the input phases. The current in the other two phases would be significantly lower.

The values of maximum input current are stated for a supply with a 2 % negative phase-sequence imbalance and rated at the maximum supply fault current given in Table 4-5.

**Table 4-5 Supply fault current used to calculate maximum input currents**

Model	Symmetrical fault level (kA)
All sizes	100

The nominal cable sizes given in section 2.4 *Ratings* are only a guide. Refer to local wiring regulations for the correct size of cables. In some cases a larger cable is required to avoid excessive voltage drop.

#### NOTE

The nominal output cable sizes in section 2.4 *Ratings* on page 14 assume that the motor maximum current matches that of the drive. Where a motor of reduced rating is used the cable rating may be chosen to match that of the motor. To ensure that the motor and cable are protected against over-load, the drive must be programmed with the correct motor rated current.



WARNING

#### Fuses

The AC supply to the drive must be installed with suitable protection against overload and short-circuits. Nominal fuse ratings are shown in section 2.4 *Ratings* on page 14. Failure to observe this requirement will cause risk of fire.

A fuse or other protection must be included in all live connections to the AC supply.

### Fuse types

The fuse voltage rating must be suitable for the drive supply voltage.

## 4.10 Output circuit and motor protection

The output circuit has fast-acting electronic short-circuit protection which limits the fault current to typically no more than five times the rated output current, and interrupts the current in approximately 20  $\mu$ s. No additional short-circuit protection devices are required.

The drive provides overload protection for the motor and its cable. For this to be effective, *Rated Current (00.046)* must be set to suit the motor.



WARNING

*Rated Current (00.046)* must be set correctly to avoid a risk of fire in the event of motor overload.

There is also provision for the use of a motor thermistor to prevent over-heating of the motor, e.g. due to loss of cooling.

### 4.10.1 Motor cable types

Since capacitance in the motor cable causes loading on the output of the drive, ensure the cable length does not exceed the values given in Table 5-22 *Maximum motor cable lengths* on page 86. Use 105 °C (221 °F) (UL 60/75 °C temp rise) PVC-insulated cable with copper conductors having a suitable voltage rating, for the following power connections:

- AC supply to external EMC filter (when used)
- AC supply (or external EMC filter) to drive
- Drive to motor
- Drive to braking resistor

### 4.10.2 High-capacitance / reduced diameter cables

The maximum cable length is reduced from that shown in Table 5-22 *Maximum motor cable lengths* on page 86 if high capacitance or reduced diameter motor cables are used.

Most cables have an insulating jacket between the cores and the armor or shield; these cables have a low capacitance and are recommended. Cables that do not have an insulating jacket tend to have high capacitance; if a cable of this type is used, the maximum cable length is half that quoted in the tables, (Figure 4-6 shows how to identify the two types).

**Figure 4-6 Cable construction influencing the capacitance**

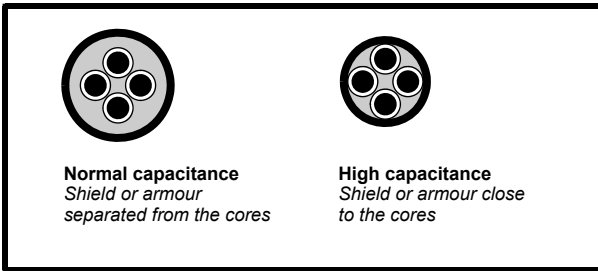

The maximum motor cable lengths specified in section 5.1.22 *Maximum motor cable lengths* on page 86 is shielded and contains four cores. Typical capacitance for this type of cable is 130 pF/m (i.e. from one core to all others and the shield connected together).

### 4.10.3 Motor winding voltage

The PWM output voltage can adversely affect the inter-turn insulation in the motor. This is because of the high rate of change of voltage, in conjunction with the impedance of the motor cable and the distributed nature of the motor winding.

For normal operation with AC supplies up to 500 Vac and a standard motor with a good quality insulation system, there is no need for any special precautions. In case of doubt the motor supplier should be consulted. Special precautions are recommended under the following conditions, but only if the motor cable length exceeds 10 m:

- AC supply voltage exceeds 500 V
- DC supply voltage exceeds 670 V, i.e regenerative / AFE supply.
- Operation of 400 V drive with continuous or very frequent sustained braking
- Multiple motors connected to a single drive

For multiple motors, the precautions given in section 4.10.4 *Multiple motors* should be followed.

For the other cases listed, it is recommended that an inverter-rated motor be used taking into account the voltage rating of the inverter. This has a reinforced insulation system intended by the manufacturer for repetitive fast-rising pulsed voltage operation.

Users of 575 V NEMA rated motors should note that the specification for inverter-rated motors given in NEMA MG1 section 31 is sufficient for motoring operation but not where the motor spends significant periods braking. In that case an insulation peak voltage rating of 2.2 kV is recommended.

If it is not practical to use an inverter-rated motor, an output choke (inductor) should be used. The recommended type is a simple iron-cored component with a reactance of about 2 %. The exact value is not critical. This operates in conjunction with the capacitance of the motor cable to increase the rise-time of the motor terminal voltage and prevent excessive electrical stress.

#### 4.10.4 Multiple motors

##### Open-loop only

If the drive is to control more than one motor, one of the fixed V/F modes should be selected (Pr **05.014** = Fixed or Squared). Make the motor connections as shown in Figure 4-7 and Figure 4-8. The maximum motor cable lengths specified in section 5.1.22 *Maximum motor cable lengths* on page 86 apply to the sum of the total cable lengths from the drive to each motor.

It is recommended that each motor is connected through a protection relay since the drive cannot protect each motor individually. For  $\Delta$  connection, a sinusoidal filter or an output inductor must be connected as shown in Figure 4-8, even when the cable lengths are less than the maximum permissible. For high DC voltages or when supplied by a regen system, a sinusoidal filter is recommended. For details of filter or inductor sizes refer to the supplier of the drive.

**Figure 4-7 Preferred chain connection for multiple motors**

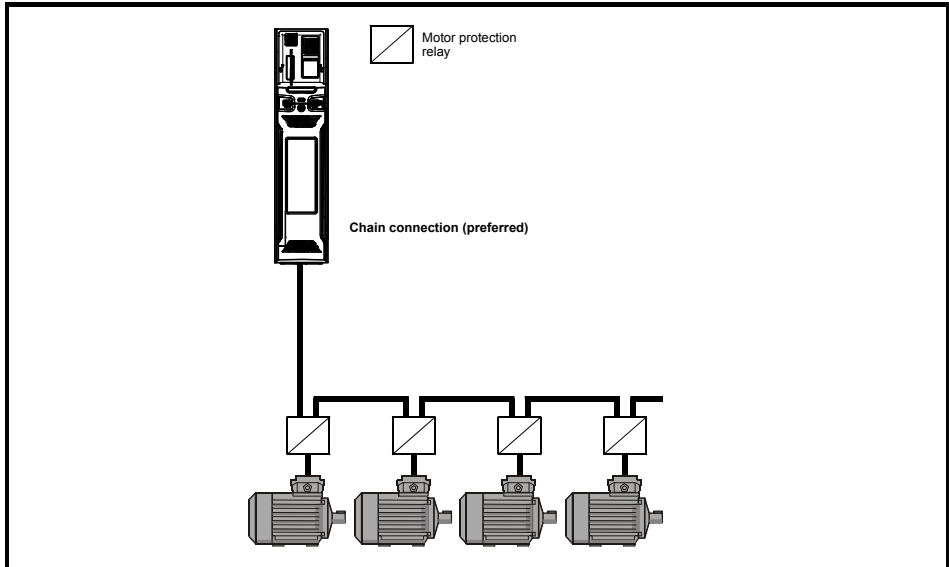

**Figure 4-8 Alternative connection for multiple motors**

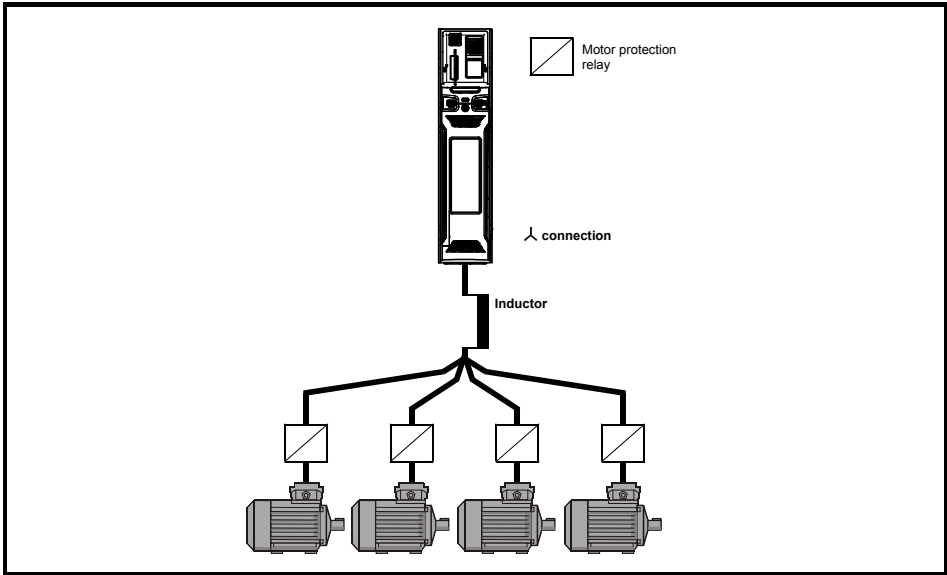

#### 4.10.5 λ / Δ motor operation

The voltage rating for λ and Δ connections of the motor should always be checked before attempting to run the motor.

The default setting of the motor rated voltage parameter is the same as the drive rated voltage, i.e.

400 V drive 400 V rated voltage

230 V drive 230 V rated voltage

A typical 3 phase motor would be connected in λ for 400 V operation or Δ for 230 V operation, however, variations on this are common e.g. λ 690 V Δ 400 V.

Incorrect connection of the windings will cause severe under or over fluxing of the motor, leading to a very poor output torque or motor saturation and overheating respectively.

#### 4.10.6 Output contactor



If the cable between the drive and the motor is to be interrupted by a contactor or circuit breaker, ensure that the drive is disabled before the contactor or circuit breaker is opened or closed. Severe arcing may occur if this circuit is interrupted with the motor running at high current and low speed.

A contactor is sometimes required to be installed between the drive and motor for safety purposes.

The recommended motor contactor is the AC3 type.

Switching of an output contactor should only occur when the output of the drive is disabled.

Opening or closing of the contactor with the drive enabled will lead to:

1. OI ac trips (which cannot be reset for 10 seconds)
2. High levels of radio frequency noise emission
3. Increased contactor wear and tear

The Drive Enable terminal (terminal 31 on *Unidrive M700 / M701 / HS70 / HS71* and terminal 11 & 13 on *Unidrive M702 / HS72*) when opened provides a Safe Torque Off function. This can in many cases replace output contactors.

For further information see the *Control User Guide*.

## 4.11 Braking

Braking occurs when the drive is decelerating the motor, or is preventing the motor from gaining speed due to mechanical influences. During braking, energy is returned to the drive from the motor.

When motor braking is applied by the drive, the maximum regenerated power that the drive can absorb is equal to the power dissipation (losses) of the drive.

When the regenerated power is likely to exceed these losses, the DC bus voltage of the drive increases. Under default conditions, the drive brakes the motor under PI control, which extends the deceleration time as necessary in order to prevent the DC bus voltage from rising above a user defined set-point.

If the drive is expected to rapidly decelerate a load, or to hold back an overhauling load, a braking resistor must be installed.

Table 4-6 shows the default DC voltage level at which the drive turns on the braking transistor. However the braking resistor turn on and the turn off voltages are programmable with *Braking IGBT Lower Threshold* (06.073) and *Braking IGBT Upper Threshold* (06.074).

**Table 4-6 Default braking transistor turn on voltage**

Drive voltage rating	DC bus voltage level
400 V	780 V
575 V	930 V
690 V	1120 V

**NOTE** When a braking resistor is used, Pr **00.015** should be set to Fast Ramp Mode.



### High temperatures

Braking resistors can reach high temperatures. Locate braking resistors so that damage cannot result. Use cable having insulation capable of withstanding high temperatures.

#### 4.11.1 Braking resistor



### Overload protection

When a braking resistor is used, it is essential that an overload protection device is incorporated in the braking resistor circuit; this is described in *Figure 4-9 on page 57*.

When a braking resistor is to be mounted outside the enclosure, ensure that it is mounted in a ventilated metal housing that will perform the following functions:

- Prevent inadvertent contact with the resistor
- Allow adequate ventilation for the resistor

When compliance with EMC emission standards is required, external connection requires the cable to be armored or shielded, since it is not fully contained in a metal enclosure. See section 4-10 *General EMC enclosure layout showing ground connections* on page 60 for further details.

Internal connection does not require the cable to be armored or shielded.

**Table 4-7 Minimum resistance values and peak power rating for the braking resistor at 40 °C (104 °F)**

<b>Model</b>	<b>Minimum resistance*</b> <b>Ω</b>	<b>Instantaneous power rating</b> <b>kW</b>	<b>Continuous power rating</b> <b>kW</b>
<b>400 V</b>			
11403770	1.83	369.4	185
11404170	1.2	563.4	200
11404640	1.2	563.4	250
<b>575 V</b>			
11502000	1.83	525.2	150
11502540	1.83	525.2	185
11502850	1.83	525.2	225
<b>690 V</b>			
11602100	2.2	633.6	185
11602380	2.2	633.6	200
11602630	2.2	633.6	250

\* Resistor tolerance: ±10 %.

For high-inertia loads or under continuous braking, the continuous power dissipated in the braking resistor may be as high as the power rating of the drive. The total energy dissipated in the braking resistor is dependent on the amount of energy to be extracted from the load.

The instantaneous power rating refers to the short-term maximum power dissipated during the on intervals of the pulse width modulated braking control cycle. The braking resistor must be able to withstand this dissipation for short intervals (milliseconds). Higher resistance values require proportionately lower instantaneous power ratings.

In most applications, braking occurs only occasionally. This allows the continuous power rating of the braking resistor to be much lower than the power rating of the drive. It is therefore essential that the instantaneous power rating and energy rating of the braking resistor are sufficient for the most extreme braking duty that is likely to be encountered.

Optimization of the braking resistor requires careful consideration of the braking duty.

Select a value of resistance for the braking resistor that is not less than the specified minimum resistance. Larger resistance values may give a cost saving, as well as a safety benefit in the event of a fault in the braking system. Braking capability will then be reduced, which could cause the drive to trip during braking if the value chosen is too large.

#### **Thermal protection circuit for the braking resistor**

The thermal protection circuit must disconnect the AC supply from the drive if the resistor becomes overloaded due to a fault. Figure 4-9 shows a typical circuit arrangement.



**Figure 4-9 Typical protection circuit for a braking resistor**

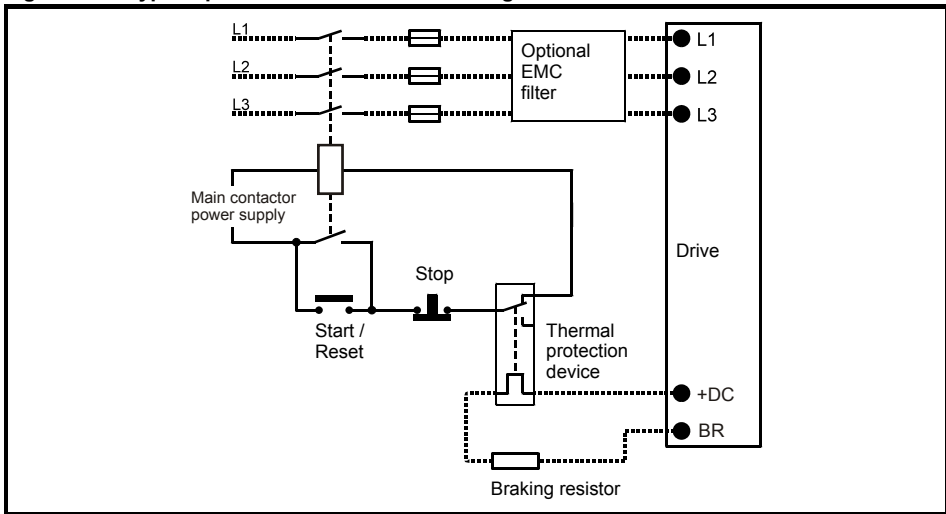

See Figure 4-1 on page 43 for the location of the +DC and braking resistor connection.

#### 4.11.2 Braking resistor software overload protection

The drive software contains an overload protection function for a braking resistor. In order to enable and set-up this function, it is necessary to enter three values into the drive:

- *Braking Resistor Rated Power* (10.030)
- *Braking Resistor Thermal Time Constant* (10.031)
- *Braking Resistor Resistance* (10.061)

This data should be obtained from the manufacturer of the braking resistors.

Pr **10.039** gives an indication of braking resistor temperature based on a simple thermal model. Zero indicates the resistor is close to ambient and 100 % is the maximum temperature the resistor can withstand. A 'Brake Resistor' alarm is given if this parameter is above 75 % and the braking IGBT is active. A Brake R Too Hot trip will occur if Pr **10.039** reaches 100 %, when Pr **10.037** is set to 0 (default value) or 1.

If Pr **10.037** is equal to 2 or 3, a Brake R Too Hot trip will not occur when Pr **10.039** reaches 100 %, but instead the braking IGBT will be disabled until Pr **10.039** falls below 95 %. This option is intended for applications with parallel connected DC buses where there are several braking resistors, each of which cannot withstand full DC bus voltage continuously. With this type of application it is unlikely the braking energy will be shared equally between the resistors because of voltage measurement tolerances within the individual drives. Therefore with Pr **10.037** set to 2 or 3, then as soon as a resistor has reached its maximum temperature the drive will disable the braking IGBT, and another resistor on another drive will take up the braking energy. Once Pr **10.039** has fallen below 95 % the drive will allow the braking IGBT to operate again.

See the *Parameter Reference Guide* for more information on Pr **10.030**, Pr **10.031**, Pr **10.037** and Pr **10.039**.

This software overload protection should be used in addition to an external overload protection device.

## 4.12 Ground leakage

The size 11E drive has an internal EMC capacitor installed, this capacitor is not removable. The ground leakage current is as follows:

- 56 mA AC at 400 V 50 Hz (proportional to supply voltage and frequency)
- 18  $\mu$ A DC with a 600 V DC bus (33 M $\Omega$ )

Note there is an internal voltage surge protection device connected to ground. Under normal circumstances this carries negligible current.



The ground leakage current is high. A permanent fixed ground connection must be provided, or other suitable measures taken to prevent a safety hazard occurring if the connection is lost.

### 4.12.1 Use of residual current device (RCD)

There are three common types of ELCB / RCD:

1. AC - detects AC fault currents
2. A - detects AC and pulsating DC fault currents (provided the DC current reaches zero at least once every half cycle)
3. B - detects AC, pulsating DC and smooth DC fault currents
  - Type AC should never be used with drives.
  - Type A can only be used with single phase drives
  - Type B must be used with three phase drives



Only type B ELCB / RCD are suitable for use with 3 phase inverter drives.

If an external EMC filter is used, a delay of at least 50 ms should be incorporated to ensure spurious trips are not seen. The leakage current is likely to exceed the trip level if all of the phases are not energized simultaneously.

## 4.13 EMC (Electromagnetic compatibility)

The requirements for EMC are divided into three levels in the following three sections:

**Section 4.13.2, General requirements** for all applications, to ensure reliable operation of the drive and minimise the risk of disturbing nearby equipment. The immunity standards specified in section 11 will be met, but no specific emission standards. Note also the special requirements given in *Surge immunity of control circuits - long cables and connections outside a building* on page 72 for increased surge immunity of control circuits where control wiring is extended.

**Section 4.13.3, Requirements for meeting the EMC standard for power drive systems, IEC61800-3 (EN 61800-3:2004+A1:2012).**

**Section 4.13.4, Requirements for meeting the generic emission standards for the industrial environment, IEC61000-6-4, EN 61000-6-4:2007+A1:2011.**

The recommendations of section 4.13.2 will usually be sufficient to avoid causing disturbance to adjacent equipment of industrial quality. If particularly sensitive equipment is to be used nearby, or in a non-industrial environment, then the recommendations of section 4.13.3 or section 4.13.4 should be followed to give reduced radio-frequency emission.

In order to ensure the installation meets the various emission standards described in:

- The EMC data sheet available from the supplier of the drive
- The Declaration of Conformity at the front of this manual

The correct external EMC filter must be used, and all of the guidelines in *section 4.13.2* and *section 4.13.4* must be followed.



### High ground leakage current

When an EMC filter is used, a permanent fixed ground connection must be provided which does not pass through a connector or flexible power cord. This includes the internal EMC filter.

#### NOTE

The installer of the drive is responsible for ensuring compliance with the EMC regulations that apply where the drive is to be used.

### 4.13.1 Internal EMC filter

The size 11E drive has an internal EMC capacitor installed, this capacitor is not removable. This (and the lack of a negative DC terminal) mean that the size 11E drive is not suitable for use as part of a regen system.



The non removable internal EMC filter means the drive is not suitable for use with ungrounded (IT) supplies unless additional motor ground fault protection is installed. For details of ground fault protection contact the supplier of the drive.

The internal EMC filter reduces radio-frequency emission into the line power supply. Where the motor cable is short, it permits the requirements of EN 61800-3:2004+A1:2012 to be met for the second environment - see section 4.13.3. For longer motor cables the filter continues to provide a useful reduction in emission level, and when used with any length of shielded motor cable up to the limit for the drive, it is unlikely that nearby industrial equipment will be disturbed.

## 4.13.2 General requirements for EMC

### Ground (earth) connections

The grounding arrangements should be in accordance with Figure 4-10, which shows a single drive on a back-plate with or without an additional enclosure.

Figure 4-10 shows how to manage EMC when using an unshielded motor cable. However a shielded cable is preferable, in which case it should be installed as shown in section 4.13.4 *Compliance with generic emission standards* on page 65.

**Figure 4-10** General EMC enclosure layout showing ground connections

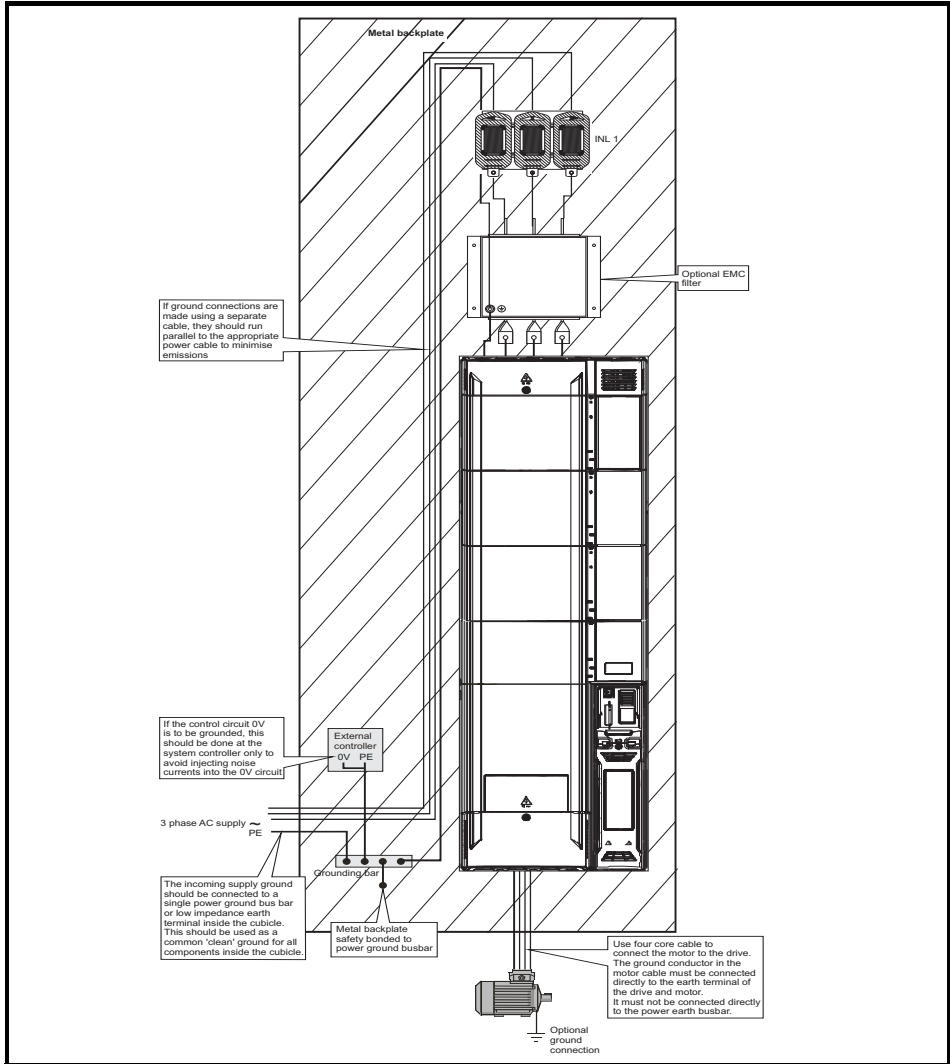

## Cable layout

Figure 4-11 indicates the clearances which should be observed around the drive and related 'noisy' power cables by all sensitive control signals / equipment.

**Figure 4-11 Drive cable clearances**

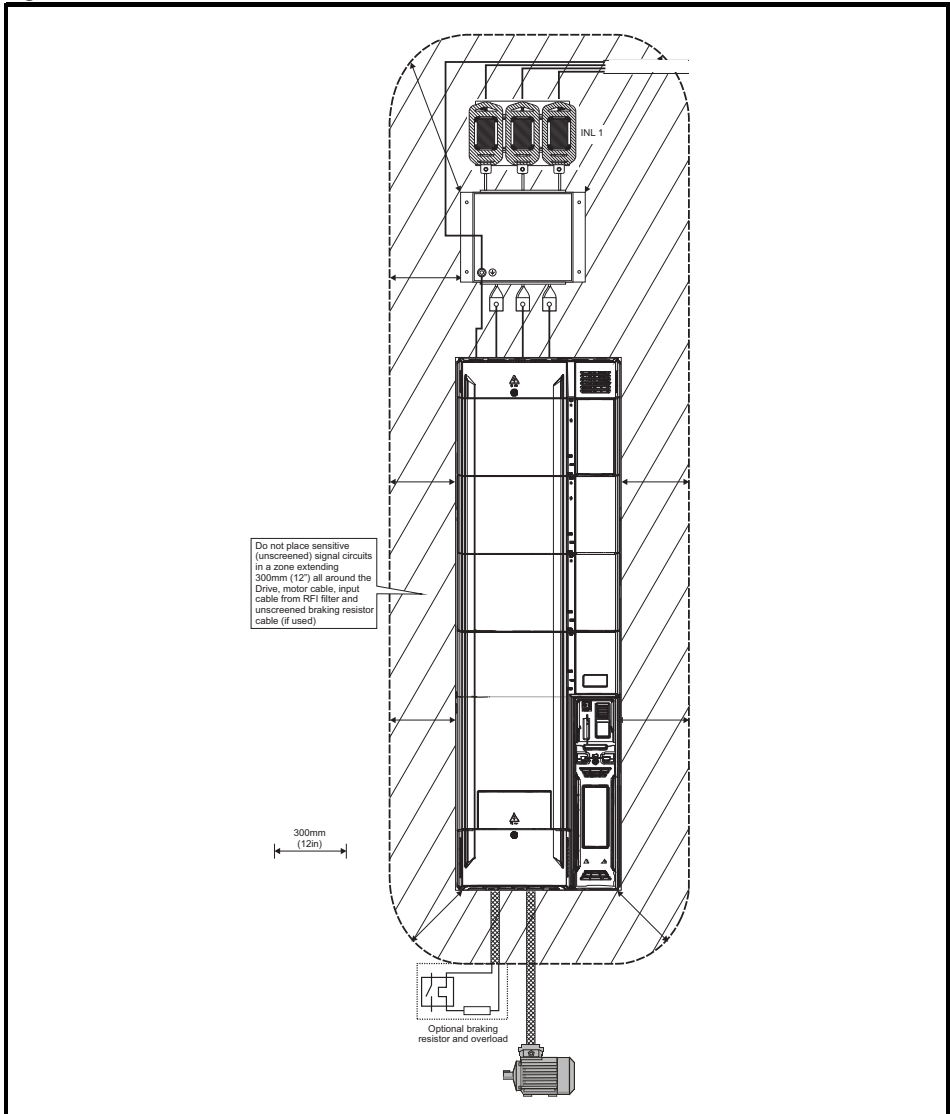

### NOTE

Any signal cables which are carried inside the motor cable (i.e. motor thermistor, motor brake) will pick up large pulse currents via the cable capacitance. The shield of these signal cables must be connected to ground close to the motor cable, to avoid this noise current spreading through the control system.

## Feedback device cable shielding

Shielding considerations are important for PWM drive installations due to the high voltages and currents present in the output (motor) circuit with a very wide frequency spectrum, typically from 0 to 20 MHz.

The following guidance is divided into two parts:

1. Ensuring correct transfer of data without disturbance from electrical noise originating either within the drive or from outside.
2. Additional measures to prevent unwanted emission of radio frequency noise. These are optional and only required where the installation is subject to specific requirements for radio frequency emission control.

### To ensure correct transfer of data, observe the following:

#### Resolver connections:

- Use a cable with an overall shield and twisted pairs for the resolver signals
- Connect the cable shield to the drive 0V connection by the shortest possible link ("pigtail")
- It is generally preferable not to connect the cable shield to the resolver. However in cases where there is an exceptional level of common-mode noise voltage present on the resolver body, it may be helpful to connect the shield there. If this is done then it becomes essential to ensure the absolute minimum length of "pigtailed" at both shield connections, and possibly to clamp the cable shield directly to the resolver body and to the drive grounding bracket.
- The cable should preferably not be interrupted. If interruptions are unavoidable, ensure the absolute minimum length of "pigtail" in the shield connections at each interruption.

#### Encoder connections:

- Use a cable with the correct impedance
- Use a cable with individually shielded twisted pairs
- Connect the cable shields to 0V at both the drive and the encoder, using the shortest possible links ("pigtailed")
- The cable should preferably not be interrupted. If interruptions are unavoidable, ensure the absolute minimum length of "pigtail" in the shield connections at each interruption. Preferably, use a connection method which provides substantial metallic clamps for the cable shield terminations.

The above applies where the encoder body is isolated from the motor and where the encoder circuit is isolated from the encoder body. Where there is no isolation between the encoder circuits and the motor body, and in case of doubt, the following additional requirement must be observed. This gives the best possible noise immunity.

- The shields must be directly clamped to the encoder body (no pigtail) and to the drive grounding bracket. This may be achieved by clamping of the individual shields or by providing an additional overall shield which is clamped.

**NOTE** The recommendations of the encoder manufacturer must also be adhered to for the encoder connections.

**NOTE** In order to guarantee maximum noise immunity for any application double shielded cable as shown should be used.

In some cases single shielding of each pair of differential signals cables, or a single overall shield with individual shield on the thermistor connections is sufficient. In these cases all the shields should be connected to ground and 0V at both ends.

If the 0V is required to be left floating, a cable with individual shields and an overall shield must be used.

Figure 4-12 and Figure 4-13 illustrate the preferred construction of cable and the method of clamping. The outer sheath of the cable should be stripped back enough to allow the clamp to be installed. The shield must not be broken or opened at this point. The clamps should be installed close to the drive or feedback device, with the ground connections made to a ground plate or similar metallic ground surface

**Figure 4-12 Feedback cable, twisted pair**

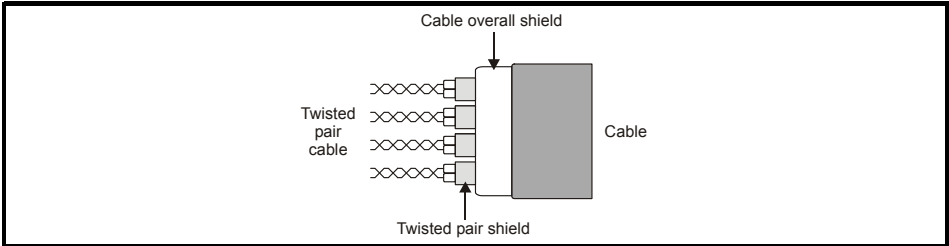

**Figure 4-13 Feedback cable connections**

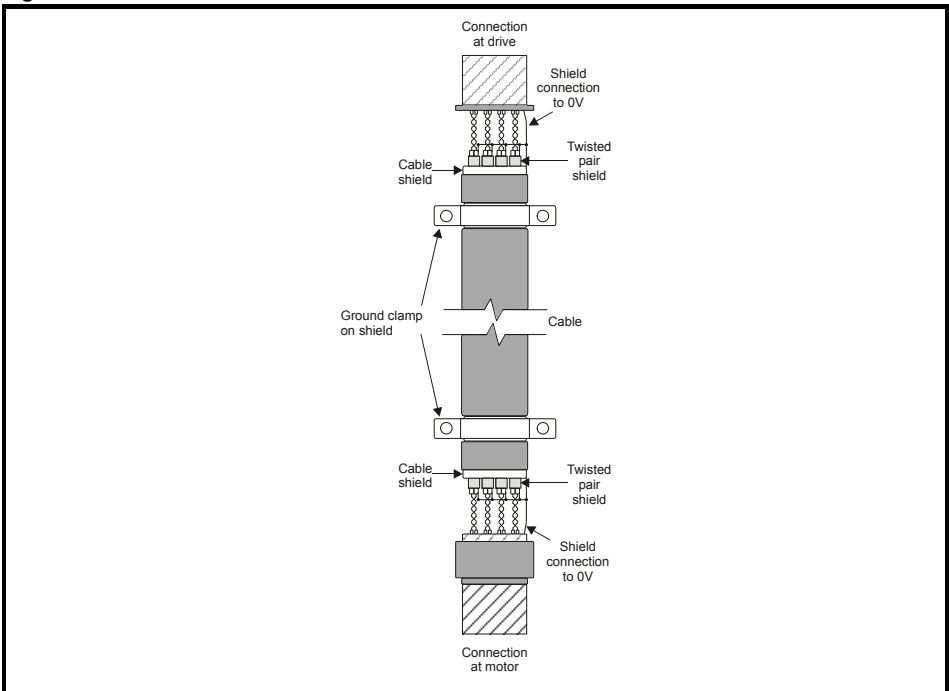

**To ensure suppression of radio frequency emission, observe the following:**

- Use a cable with an overall shield
- Clamp the overall shield to grounded metallic surfaces at both the encoder and the drive, as illustrated in Figure 4-13

### 4.13.3 Compliance with EN 61800-3:2004+A1:2012 (standard for Power Drive Systems)

Meeting the requirements of this standard depends on the environment that the drive is intended to operate in, as follows:

#### Operation in the first environment

Observe the guidelines given in section 4.13.4 *Compliance with generic emission standards* on page 65. An external EMC filter will always be required.



This is a product of the restricted distribution class according to IEC 61800-3  
In a residential environment this product may cause radio interference in which case the user may be required to take adequate measures.

#### Operation in the second environment

In all cases a shielded motor cable must be used, and an EMC filter is required for all *Unidrive M / Unidrive HS* drives with a rated input current of less than 100 A.

The drive contains an in-built filter for basic emission control. In some cases feeding the motor cables (U, V and W) once through a ferrite ring can maintain compliance for longer cable lengths. The requirements of operating in the second environment are met, depending on the motor cable length for 3 kHz switching frequency as stated in Table 4-8.

The table summarizes the performance of in-built filters when used with *Unidrive M / Unidrive HS* size 11 drives and single pairs of *Unidrive M / Unidrive HS* size 11 drives and *Unidrive M / Unidrive HS* rectifiers, assembled in the standard recommended configuration.

**Table 4-8 Second environment emission compliance**

Drive size	Filter	Voltage	Motor cable length 0 - 100 (m)
All sizes	In-built	Any	Unrestricted

#### Key:

Unrestricted: EN 61800-3:2004+A1:2012 second environment, unrestricted distribution.

For longer motor cables, an external filter is required. Where a filter is required, follow the guidelines in *section 4.13.4 Compliance with generic emission standards*.

Where a filter is not required, follow the guidelines given in section 4.13.2 *General requirements for EMC* on page 60.



The second environment typically includes an industrial low-voltage power supply network which does not supply buildings used for residential purposes. Operating the drive in this environment without an external EMC filter may cause interference to nearby electronic equipment whose sensitivity has not been appreciated. The user must take remedial measures if this situation arises. If the consequences of unexpected disturbances are severe, it is recommended that the guidelines in *section 4.13.4 Compliance with generic emission standards* be adhered to.

Detailed instructions and EMC information are given in the *Unidrive M / Unidrive HS EMC Data Sheet* which is available from the supplier of the drive.



#### 4.13.4 Compliance with generic emission standards

Use the recommended filter and shielded motor cable. Observe the layout rules given in Figure 4-14. Ensure the AC supply and ground cables are at least 100 mm from the power module and motor cable.

Figure 4-14 Supply and ground cable clearance

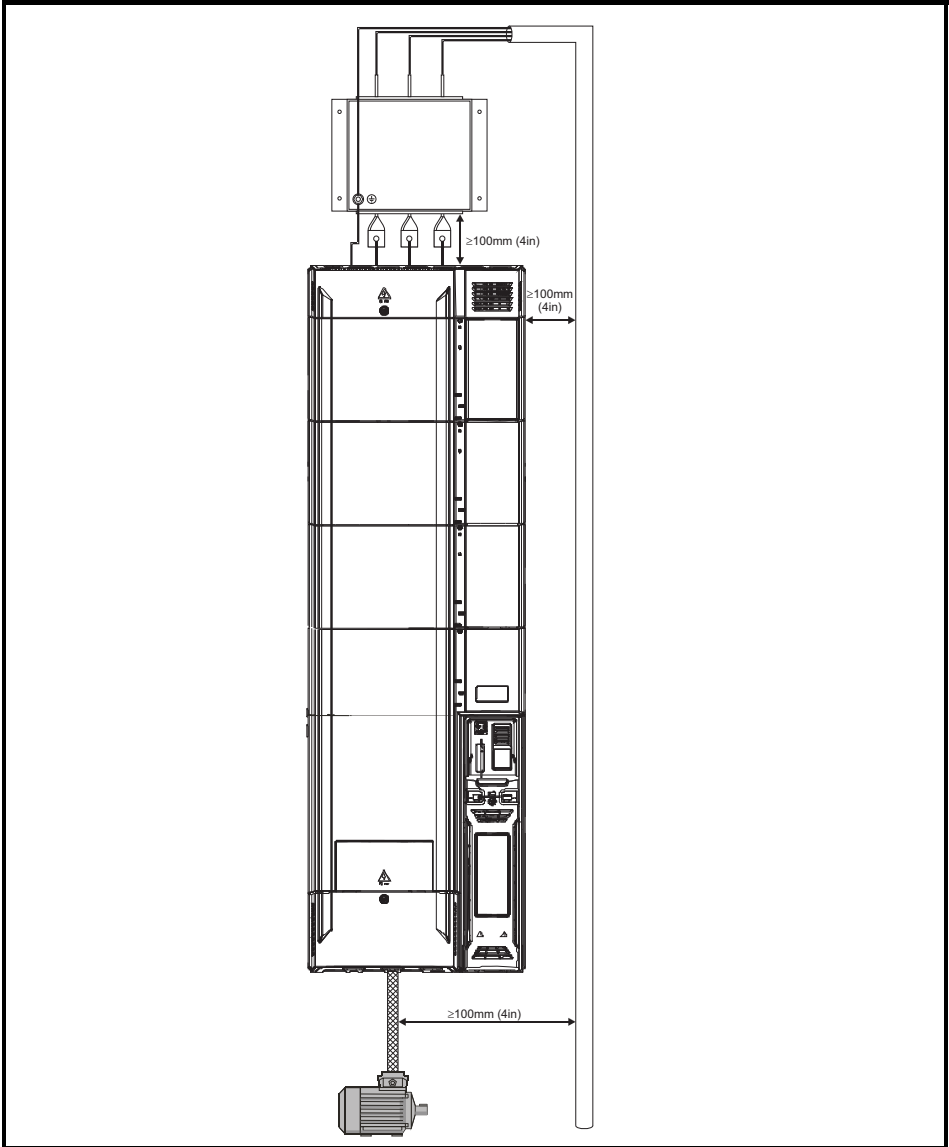

**Figure 4-15 Sensitive signal circuit clearance**

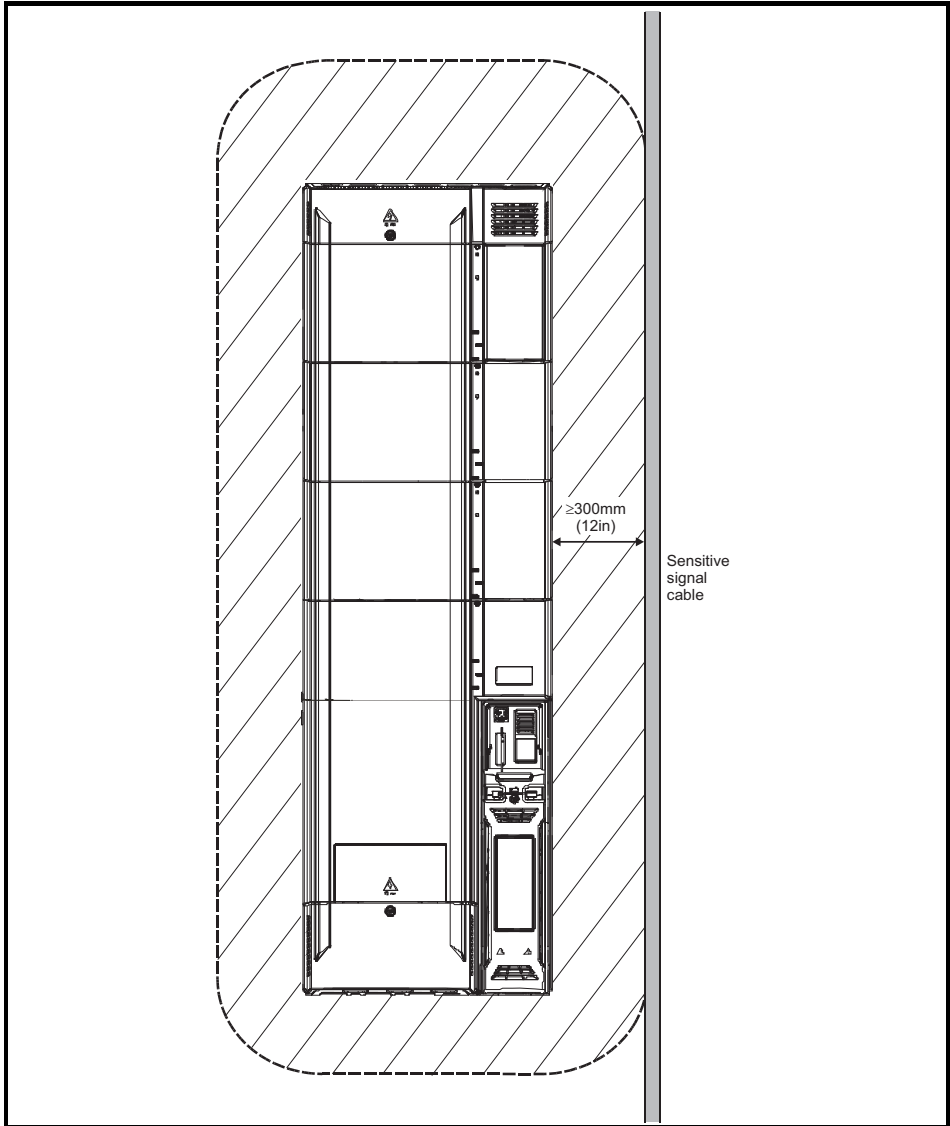

Avoid placing sensitive signal circuits in a zone 300 mm (12 in) all around the power module.

### 4.13.5 Ensure good EMC grounding.

Figure 4-16 Grounding the drive, motor cable shield and filter

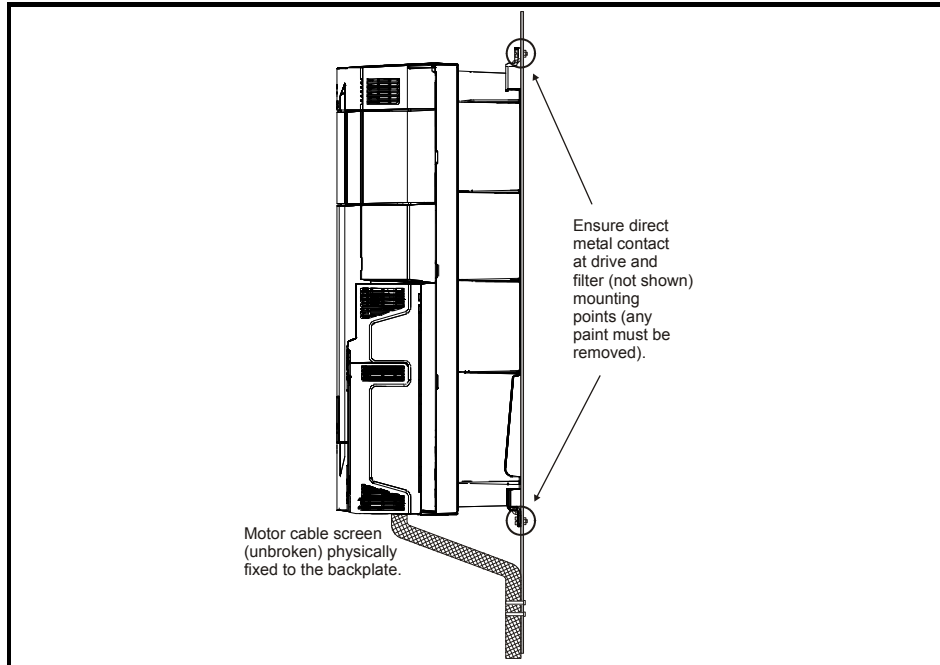

Connect the shield of the motor cable to the ground terminal of the motor frame using a link that is as short as possible and not exceeding 50 mm (2 in) long. A full 360° termination of the shield to the terminal housing of the motor is beneficial.

It is unimportant for EMC purposes whether the motor cable contains an internal (safety) ground core, or there is a separate external ground conductor, or grounding is through the shield alone. An internal ground core will carry a high noise current and therefore it must be terminated as close as possible to the shield termination.

**Figure 4-17** Grounding the motor cable shield

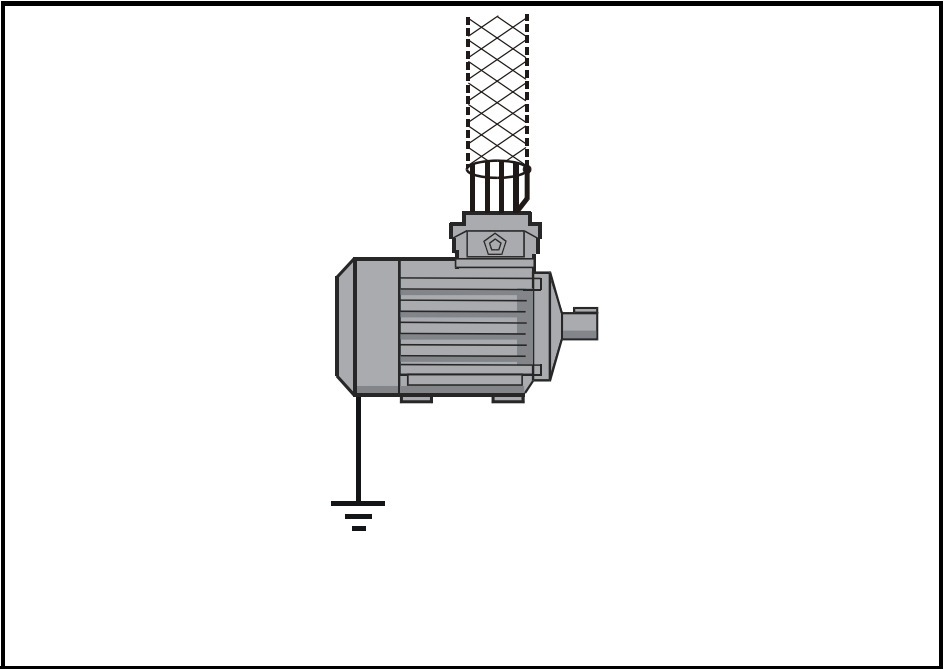

Unshielded wiring to the optional braking resistor(s) may be used, provided the wiring does not run external to the enclosure. Ensure a minimum spacing of 300 mm (12 in) from signal wiring and the AC supply wiring to the external EMC filter. Otherwise this wiring must be shielded.

**Figure 4-18 Shielding requirements of optional external braking resistor**

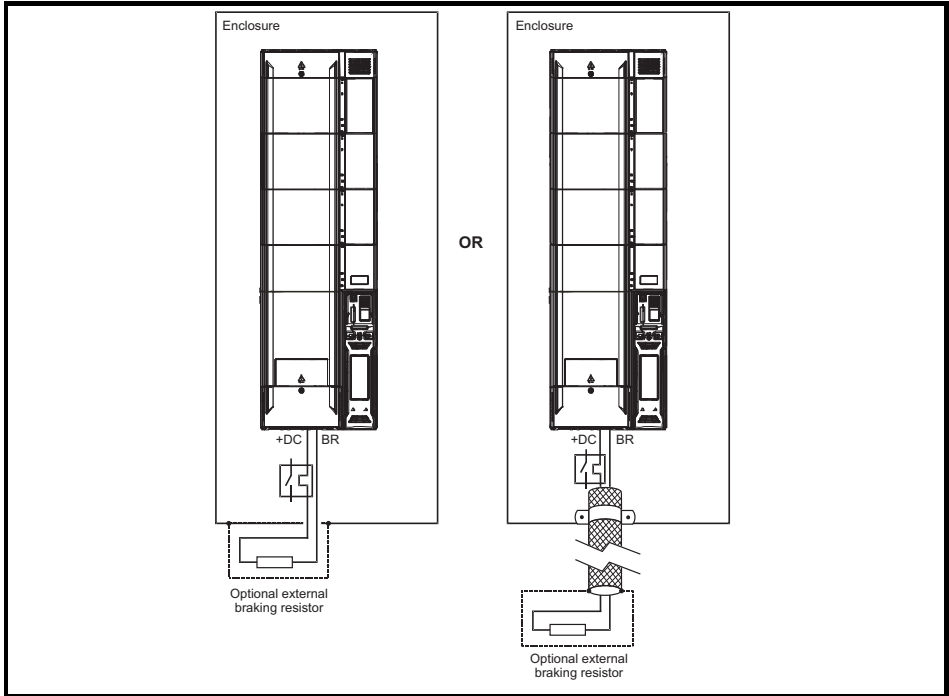

If the control wiring is to leave the enclosure, it must be shielded and the shield(s) clamped to the drive using the grounding bracket as shown in Figure 4-19. Remove the outer insulating cover of the cable to ensure the shield(s) make contact with the bracket, but keep the shield(s) intact until as close as possible to the terminals

Alternatively, wiring may be passed through a ferrite ring, part no. 3225-1004.

**Figure 4-19 Grounding of signal cable shields using the grounding bracket**

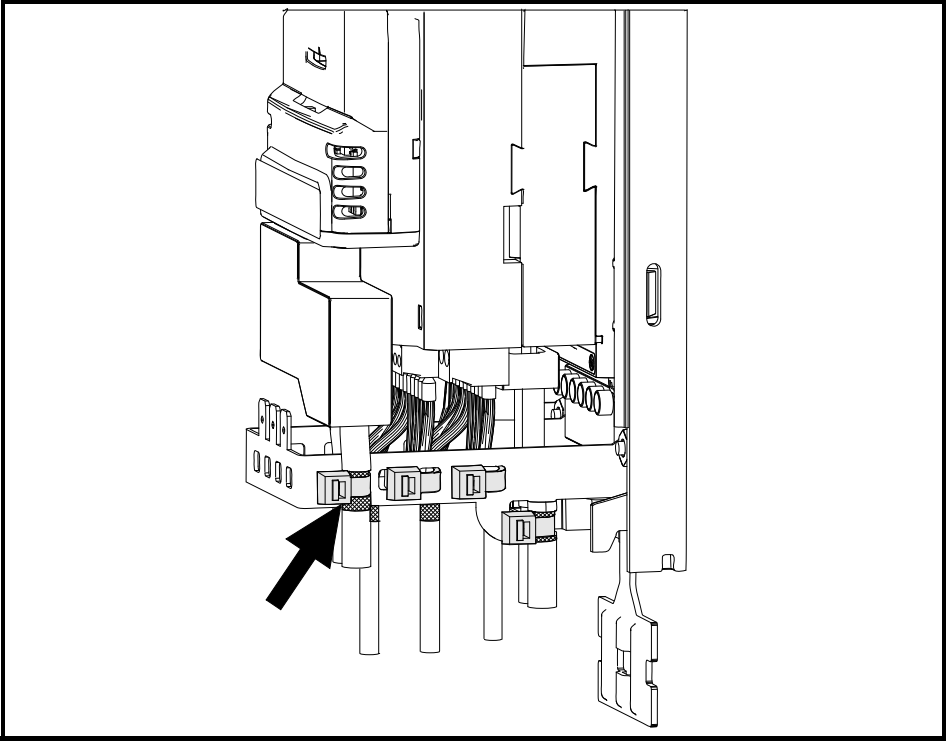

### 4.13.6 Variations in the EMC wiring

#### Interruptions to the motor cable

The motor cable should ideally be a single length of shielded or armored cable having no interruptions. In some situations it may be necessary to interrupt the cable, as in the following examples:

- Connecting the motor cable to a terminal block in the drive enclosure
- Installing a motor isolator/disconnect switch for safety when work is done on the motor

In these cases the following guidelines should be followed.

#### Terminal block in the enclosure

The motor cable shields should be bonded to the back-plate using uninsulated metal cable-clamps which should be positioned as close as possible to the terminal block. Keep the length of power conductors to a minimum and ensure that all sensitive equipment and circuits are at least 0.3m (12 in) away from the terminal block.

**Figure 4-20 Connecting the motor cable to a terminal block in the enclosure**

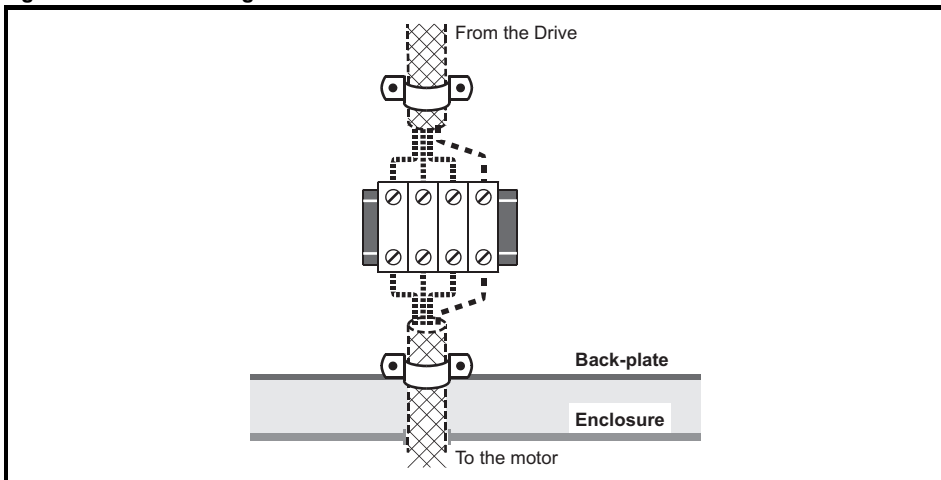

#### Using a motor isolator/disconnect-switch

The motor cable shields should be connected by a very short conductor having a low inductance. The use of a flat metal coupling-bar is recommended; conventional wire is not suitable.

The shields should be bonded directly to the coupling-bar using uninsulated metal cable-clamps. Keep the length of the exposed power conductors to a minimum and ensure that all sensitive equipment and circuits are at least 0.3 m (12 in) away.

The coupling-bar may be grounded to a known low-impedance ground nearby, for example a large metallic structure which is connected closely to the drive ground.

**Figure 4-21 Connecting the motor cable to an isolator/disconnect switch**

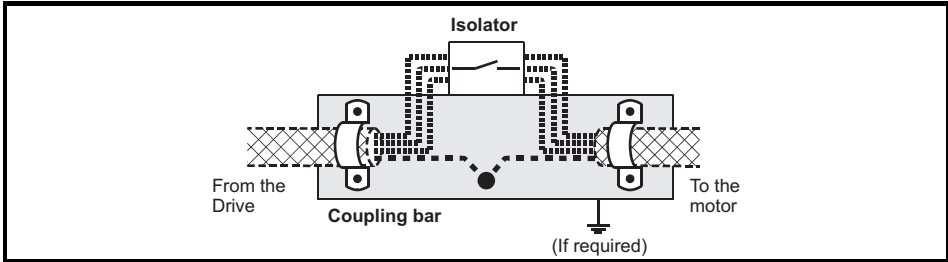

**Surge immunity of control circuits - long cables and connections outside a building**

The input/output ports for the control circuits are designed for general use within machines and small systems without any special precautions.

These circuits meet the requirements of EN 61000-6-2:2005 (1 kV surge) provided the 0V connection is not grounded.

In applications where they may be exposed to high-energy voltage surges, some special measures may be required to prevent malfunction or damage. Surges may be caused by lightning or severe power faults in association with grounding arrangements which permit high transient voltages between nominally grounded points. This is a particular risk where the circuits extend outside the protection of a building.

As a general rule, if the circuits are to pass outside the building where the drive is located, or if cable runs within a building exceed 30 m, some additional precautions are advisable. One of the following techniques should be used:

1. Galvanic isolation, i.e. do not connect the control 0V terminal to ground. Avoid loops in the control wiring, i.e. ensure every control wire is accompanied by its return (0V) wire.
2. Shielded cable with additional power ground bonding. The cable shield may be connected to ground at both ends, but in addition the ground conductors at both ends of the cable must be bonded together by a power ground cable (equipotential bonding cable) with cross-sectional area of at least 10 mm<sup>2</sup>, or 10 times the area of the signal cable shield, or to suit the electrical safety requirements of the plant. This ensures that fault or surge current passes mainly through the ground cable and not in the signal cable shield. If the building or plant has a well-designed common bonded network this precaution is not necessary.
3. Additional over-voltage suppression - for the analog and digital inputs and outputs, a zener diode network or a commercially available surge suppressor may be connected in parallel with the input circuit as shown in Figure 4-22 and Figure 4-23.

If a digital port experiences a severe surge its protective trip may operate (O.Ld1 trip code 26). For continued operation after such an event, the trip can be reset automatically by setting Pr **10.034** to 5.

**Figure 4-22 Surge suppression for digital and unipolar inputs and outputs**

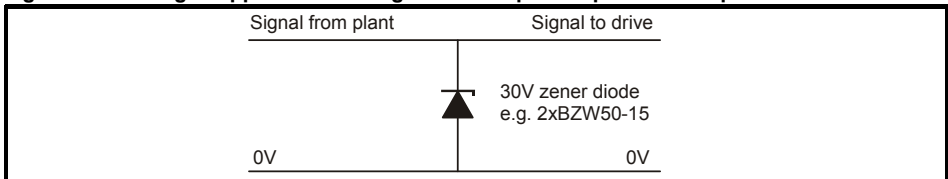



**Figure 4-23 Surge suppression for analog and bipolar inputs and outputs**

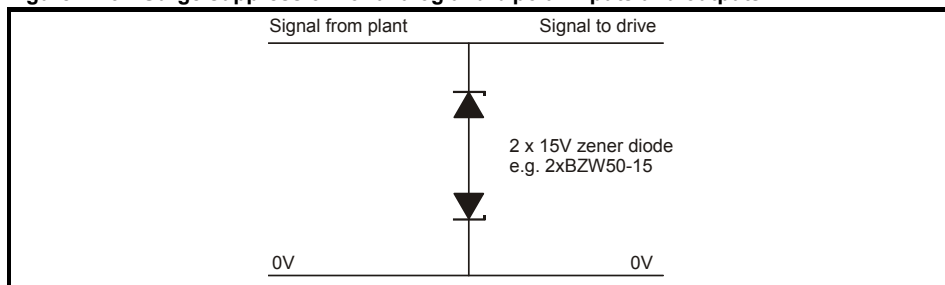

Surge suppression devices are available as rail-mounting modules, e.g. from Phoenix Contact:

Unipolar TT-UKK5-D/24 DC

Bipolar TT-UKK5-D/24 AC

These devices are not suitable for encoder signals or fast digital data networks because the capacitance of the diodes adversely affects the signal. Most encoders have galvanic isolation of the signal circuit from the motor frame, in which case no precautions are required. For data networks, follow the specific recommendations for the particular network.

# 5 Technical data

## 5.1 Drive technical data

### 5.1.1 Power and current ratings

The continuous current ratings given are for maximum 40 °C (104 °F), 1000 m altitude and 2 kHz switching frequency. Derating is required for higher switching frequencies, ambient temperature >40 °C (104 °F) and high altitude. For further information, please refer to Section 5.1.2 on page 75 and section 5.1.9 on page 80.

**Table 5-1 400 V drive ratings (380 V to 480 V ±10 %)**

Model	Normal Duty				Heavy Duty				
	Maximum continuous output current	Nominal power at 400 V	Motor power at 460 V	Peak current	Maximum continuous output current	Open loop peak current	RFC peak current	Nominal power at 400 V	Motor power at 460 V
	A	kW	hp	A	A	A	A	kW	hp
11403770	437	225	350	481	377	565	660	185	300
11404170	487	250	400	536	417	625	730	200	350
11404640	507	280	450	558	464	696	812	250	400

**Table 5-2 575 V drive ratings (500 V to 575 V ±10 %)**

Model	Normal Duty				Heavy Duty				
	Maximum continuous output current	Nominal power at 575 V	Motor power at 575 V	Peak current	Maximum continuous output current	Open loop peak current	RFC peak current	Nominal power at 575 V	Motor power at 575 V
	A	kW	hp	A	A	A	A	kW	hp
11502000	248	185	250	273	200	300	350	150	200
11502540	288	225	300	317	254	381	444	185	250
11502850	315	250	350	346	285	427	499	225	300

**Table 5-3 690 V drive ratings (500 V to 690 V ±10 %)**

Model	Normal Duty				Heavy Duty				
	Maximum continuous output current	Nominal power at 690 V	Motor power at 690 V	Peak current	Maximum continuous output current	Open loop peak current	RFC peak current	Nominal power at 690 V	Motor power at 690 V
	A	kW	hp	A	A	A	A	kW	hp
11602100	225	200	250	247	210	315	367	185	250
11602380	275	250	300	302	238	357	416	200	250
11602630	305	280	400	335	263	394	460	250	300

## 5.1.2 Power and current ratings (Derating for switching frequency and temperature)

For a full explanation of 'Normal Duty' and 'Heavy Duty' refer to the *Control User Guide*.

**Table 5-4 Maximum permissible continuous output current @ 40 °C (104 °F) ambient**

Model	Normal Duty							Heavy Duty						
	Nominal rating		Maximum permissible continuous output current (A) for the following switching frequencies					Nominal rating		Maximum permissible continuous output current (A) for the following switching frequencies				
	kW	hp	2 kHz	3 kHz	4 kHz	6 kHz	8 kHz	kW	hp	2 kHz	3 kHz	4 kHz	6 kHz	8 kHz
<b>400 V</b>														
11403770	225	350	437	437	415	336	272	185	300	377	377	372	296	245
11404170	250	400	487	460	415	336	272	200	350	417	415	372	296	245
11404640	280	400	507	460	415	336	272	250	400	464	415	372	296	245
<b>575 V</b>														
11502000	185	250	248	248	220			150	200	200	200	184		
11502540	225	300	288	265	220			185	250	254	221	184		
11502850	250	350	315	265	220			225	300	285	221	184		
<b>690 V</b>														
11602100	200	250	225	225	220			185	250	210	210	184		
11602380	250	300	275	265	220			200	250	238	221	184		
11602630	280	400	305	265	220			250	300	263	221	184		

**Table 5-5 Maximum permissible continuous output current @ 50 °C (122 °F)**

Model	Normal Duty							Heavy Duty						
	Nominal rating		Maximum permissible continuous output current (A) for the following switching frequencies					Nominal rating		Maximum permissible continuous output current (A) for the following switching frequencies				
	kW	hp	2 kHz	3 kHz	4 kHz	6 kHz	8 kHz	kW	hp	2 kHz	3 kHz	4 kHz	6 kHz	8 kHz
<b>400 V</b>														
11403770	225	350	437	415	374	298	240	185	300	377	377	343	274	223
11404170	250	400	462	415	374	298	240	200	350	415	380	343	274	223
11404640	280	400	462	415	374	298	240	250	400	418	380	343	274	223
<b>575 V</b>														
11502000	185	250	226	226	198			150	200	200	200	166		
11502540	225	300	262	241	198			185	250	240	200	166		
11502850	250	350	296	241	198			225	300	245	200	166		
<b>690 V</b>														
11602100	200	250	205	205	198			185	250	210	200	166		
11602380	250	300	250	241	198			200	250	238	200	166		
11602630	280	400	296	241	198			250	300	245	200	166		

**NOTE** 55 °C ratings are available on request

### 5.1.3 Power dissipation

Table 5-6 Losses @ 40° C (104° F) ambient

Model	Normal Duty							Heavy Duty							
	Nominal rating		Drive losses (W) taking into account any current derating for the given conditions					Nominal rating		Drive losses (W) taking into account any current derating for the given conditions					
	kW	hp	2 kHz	3 kHz	4 kHz	6 kHz	8 kHz	kW	hp	2 kHz	3 kHz	4 kHz	6 kHz	8 kHz	
<b>400 V</b>															
11403770	225	350	4182	4576	4708	4444	4246	185	300	3553	3905	4200	3960	3907	
11404170	250	400	4734	4843	4708	4444	4246	200	350	3968	4325	4200	3960	3907	
11404640	280	400	4962	4843	4708	4444	4246	250	400	4477	4325	4200	3960	3907	
<b>575 V</b>															
11502000	185	250	3391	3999	4097			150	200	2706	3204	3438			
11502540	225	300	4004	4296	4097			185	250	3481	3544	3438			
11502850	250	350	4439	4296	4097			225	300	3957	3544	3438			
<b>690 V</b>															
11602100	200	250	3225	3893	4497			185	200	3034	3670	3814			
11602380	250	300	4023	4640	4497			200	250	3470	3865	3814			
11602630	280	400	4576	4684	4540			250	300	3869	3865	3814			

**Table 5-7 Losses @ 50° C (122° F) ambient**

Model	Normal Duty						Heavy Duty							
	Nominal rating		Drive losses (W) taking into account any current derating for the given conditions				Nominal rating		Drive losses (W) taking into account any current derating for the given conditions					
	kW	hp	2 kHz	3 kHz	4 kHz	6 kHz	8 kHz	kW	hp	2 kHz	3 kHz	4 kHz	6 kHz	8 kHz
<b>400 V</b>														
11403770	225	350	4182	4329	4228	3988	3843	185	300	3553	3905	3876	3699	3634
11404170	250	400	4456	4329	4228	3988	3843	200	350	3968	3943	3876	3699	3634
11404640	280	400	4456	4329	4228	3988	3843	250	400	3974	3943	3876	3699	3634
<b>575 V</b>														
11502000	185	250	3391	3678	3532			150	200	2706	3036	2985		
11502540	225	300	3965	3678	3532			185	250	3273	3036	2985		
11502850	250	350	3965	3678	3632			225	300	3273	3036	2985		
<b>690 V</b>														
11602100	200	250	3225	3893	4048			185	200	3043	3495	3468		
11602380	250	300	4023	4186	4048			200	250	3470	3495	3468		
11602630	280	400	4421	4230	4091			250	300	3580	3495	3468		

**Table 5-8 Power losses from the front of the drive when through-panel mounted**

Frame size	Power loss
11	≤ 480 W

### 5.1.4 Temperature, humidity and cooling method

Ambient temperature operating range:

- 20 °C to 55 °C (- 4 °F to 122 °F).

Output current derating must be applied at ambient temperatures >40 °C (104 °F).

Cooling method: Forced convection

Maximum humidity: 95 % non-condensing at 40 °C (104 °F)

### 5.1.5 Supply requirements

AC supply voltage:

400 V drive: 380 V to 480 V ±10 %

575 V drive: 500 V to 575 V ±10 %

690 V drive: 500 V to 690 V ±10 %

Number of phases: 3

Maximum supply imbalance: 2 % negative phase sequence (equivalent to 3 % voltage imbalance between phases).

Frequency range: 45 to 66 Hz

For UL compliance only, the maximum supply symmetrical fault current must be limited to 100 kA

## 5.1.6 Line reactors

Table 5-9 Input line reactor ratings

Model	Model number	Current A	Inductance $\mu$ H	Overall width (W) mm	Overall depth (D) mm	Overall height (H) mm	Weight kg	Max ambient temp* $^{\circ}$ C	Max ambient temp** $^{\circ}$ C	Maximum losses W
11403770	INL 403L	420	30	300	216	264	57	40	50	289
	INL 403	557	30				57			330
11404170	INL 403	557	30				57			330
11404640	INL 403	557	30				57			330
11502000	INL 603	331	93				58			320
11502540	INL 603	331	93				58			320
11502850	INL 603	331	93				58			320
11602100	INL 603	331	93				58			320
11602380	INL 603	331	93				58			320
11602630	INL 603	331	93				58			320

\* With natural cooling.

\*\* With forced cooling = 1 m/s.

## 5.1.7 Motor requirements

No. of phases: 3

Maximum voltage:

400 V drive: 480 V

575 V drive: 575 V

690 V drive: 690 V

## 5.1.8 Storage

-40  $^{\circ}$ C (-40  $^{\circ}$ F) to +55  $^{\circ}$ C (122  $^{\circ}$ F) for long term storage, or to +70  $^{\circ}$ C (158  $^{\circ}$ F) for short term storage.

Storage time is 2 years.

Electrolytic capacitors in any electronic product have a storage period after which they require reforming or replacing.

The DC bus capacitors have a storage period of 10 years.

The low voltage capacitors on the control supplies typically have a storage period of 2 years and are thus the limiting factor.

Low voltage capacitors cannot be reformed due to their location in the circuit and thus may require replacing if the drive is stored for a period of 2 years or greater without power being applied.

It is therefore recommended that drives are powered up for a minimum of 1 hour after every 2 years of storage. This process allows the drive to be stored for a further 2 years.

### 5.1.9 Altitude

Altitude range: 0 to 3,000 m (9,900 ft), subject to the following conditions:

1,000 m to 3,000 m (3,300 ft to 9,900 ft) above sea level: de-rate the maximum output current from the specified figure by 1% per 100 m (330 ft) above 1,000 m (3,300 ft)

For example at 3,000 m (9,900 ft) the output current of the drive would have to be de-rated by 20 %.

### 5.1.10 IP / UL Rating

The drive is rated to IP20 pollution degree 2 (dry, non-conductive contamination only) (NEMA 1). However, it is possible to configure the drive to achieve IP55 rating (NEMA 12) at the rear of the heatsink for through-panel mounting (some current derating is required).

The IP rating of a product is a measure of protection against ingress and contact to foreign bodies and water. It is stated as IP XX, where the two digits (XX) indicate the degree of protection provided as shown in Table 5-10.

**Table 5-10 IP Rating degrees of protection**

First digit		Second digit	
Protection against foreign bodies and access to hazardous parts		Protection against ingress of water	
0	Non-protected	0	Non-protected
1	Protected against solid foreign objects of 50 mm Ø and greater (back of a hand)	1	Protected against vertically falling water drops
2	Protected against solid foreign objects of 12.5mm Ø and greater (finger)	2	Protected against vertically falling water drops when enclosure tilted up to 15 °
3	Protected against solid foreign objects of 2.5 mm Ø and greater (tool)	3	Protected against spraying water
4	Protected against solid foreign objects of 1.0mm Ø and greater (wire)	4	Protected against splashing water
5	Dust-protected (wire)	5	Protected against water jets
6	Dust-tight (wire)	6	Protected against powerful water jets
7	-	7	Protected against the effects of temporary immersion in water
8	-	8	Protected against the effects of continuous immersion in water

**Table 5-11 UL enclosure ratings**

UL rating	Description
Type 1	Enclosures are intended for indoor use, primarily to provide a degree of protection against limited amounts of falling dirt.
Type 12	Enclosures are intended for indoor use, primarily to provide a degree of protection against dust, falling dirt and dripping non-corrosive liquids.

### 5.1.11 Corrosive gasses

Concentrations of corrosive gases must not exceed the levels given in:

- Table A2 of EN 50178:1998
- Class 3C2 of IEC 60721-3-3

This corresponds to the levels typical of urban areas with industrial activities and/or heavy traffic, but not in the immediate neighborhood of industrial sources with chemical emissions.



### 5.1.12 RoHS compliance

The drive meets EU directive 2011/65/EU for RoHS compliance.

### 5.1.13 Vibration

Maximum recommended continuous vibration level 0.14 g r.m.s. broad-band 5 to 200 Hz.

#### NOTE

This is the limit for broad-band (random) vibration. Narrow-band vibration at this level which coincides with a structural resonance could result in premature failure.

#### Bump Test

Testing in each of three mutually perpendicular axes in turn.

Referenced standard: IEC 60068-2-29: Test Eb:

Severity: 18 g, 6 ms, half sine

No. of Bumps: 600 (100 in each direction of each axis)

#### Random Vibration Test

Testing in each of three mutually perpendicular axes in turn.

Referenced standard: IEC 60068-2-64: Test Fh:

Severity: 1.0 m<sup>2</sup>/s<sup>3</sup> (0.01 g<sup>2</sup>/Hz) ASD from 5 to 20 Hz

-3 dB/octave from 20 to 200 Hz

Duration: 30 minutes in each of 3 mutually perpendicular axes.

#### Sinusoidal Vibration Test

Testing in each of three mutually perpendicular axes in turn.

Referenced standard: IEC 60068-2-6: Test Fc:

Frequency range: 5 to 500 Hz

Severity: 3.5 mm peak displacement from 5 to 9 Hz

10 m/s<sup>2</sup> peak acceleration from 9 to 200 Hz

15 m/s<sup>2</sup> peak acceleration from 200 to 500 Hz

Sweep rate: 1 octave/minute

Duration: 15 minutes in each of 3 mutually perpendicular axes.

EN 61800-5-1:2007, Section 5.2.6.4. referring to IEC 60068-2-6

Frequency range: 10 to 150 Hz

Amplitude: 10 to 57 Hz at 0.075 mm pk

57 to 150 Hz at 1g p

Sweep rate: 1 octave/minute

Duration: 10 sweep cycles per axis in each of 3 mutually perpendicular axes

### 5.1.14 Starts per hour

By electronic control: unlimited

By interrupting the AC supply: ≤20 (equally spaced)

### 5.1.15 Start up time

This is the time taken from the moment of applying power to the drive, to the drive being ready to run the motor:

Size 11: 5 s

## 5.1.16 Output frequency / speed range

### Unidrive Mxxx models:

In all operating modes (Open loop, RFC-A, RFC-S) the maximum output frequency is limited to 550 Hz.

### Unidrive HSxx models:

In open loop mode the maximum achievable output frequency is 3,000 Hz.

In RFC-A and RFC-S modes, the maximum achievable output frequency is 1,250Hz.

In RFC-S mode the speed is also limited by the voltage constant (Ke) of the motor unless field weakening operation is enabled. Ke is a specific constant for the servo motor being used. It can normally be found on the motor data sheet in V/k rpm (volts per 1,000 rpm).

It is recommended that a minimum ratio of 12:1 is maintained between the switching frequency and the maximum output frequency to maintain the quality of the output waveform. If this minimum ratio is exceeded, extra motor losses will result due to the increased harmonic content of the output waveform.

## 5.1.17 Accuracy and resolution

### Speed:

The absolute frequency and speed accuracy depends on the accuracy of the crystal used with the drive microprocessor. The accuracy of the crystal is 100 ppm, and so the absolute frequency/speed accuracy is 100 ppm (0.01 %) of the reference, when a preset speed is used. If an analog input is used the absolute accuracy is further limited by the absolute accuracy of the analog input.

The following data applies to the drive only; it does not include the performance of the source of the control signals.

#### Open loop resolution:

Preset frequency reference: 0.1 Hz

Precision frequency reference: 0.001 Hz

#### Closed loop resolution

Preset speed reference: 0.1 rpm

Precision speed reference: 0.001 rpm

Analog input 1: 11 bit plus sign

Analog input 2: 11 bit plus sign

### Current:

The resolution of the current feedback is 10 bit plus sign.

Accuracy: typical 2 %

worst case 5 %

## 5.1.18 Acoustic noise

The heatsink fan generates the majority of the sound pressure level at 1 m produced by the drive. The heatsink fan is a variable speed fan. The drive controls the speed at which the fan runs based on the temperature of the heatsink and the drive's thermal model system.

Table 5-12 gives the sound pressure level at 1 m produced by the drive for the heatsink fan running at the maximum and minimum speeds.

**Table 5-12 Acoustic noise data**

Max speed dBA	Min speed dBA
82.5	58

### 5.1.19 Overall dimensions

H	Height including surface mounting brackets
W	Width
D	Projection forward of panel when surface mounted
F	Projection forward of panel when through-panel mounted
R	Projection rear of panel when through-panel mounted

**Table 5-13 Overall drive dimensions**

Size	Dimension				
	H	W	D	F	R
11E	1242 mm (48.9 in)	310 mm (12.21 in)	313 mm (12.32 in)	190 mm (7.48 in)	123 mm (4.84 in)

### 5.1.20 Weights

**Table 5-14 Overall drive weights**

Size	Model	kg	lb
11E	All variants	63	138.9

### 5.1.21 Input current, fuse and cable size ratings

The input current is affected by the supply voltage and impedance.

#### Typical input current

The values of typical input current are given to aid calculations for power flow and power loss.

The values of typical input current are stated for a balanced supply.

#### Maximum continuous input current

The values of maximum continuous input current are given to aid the selection of cables and fuses. These values are stated for the worst case condition with the unusual combination of stiff supply with bad balance. The value stated for the maximum continuous input current would only be seen in one of the input phases. The current in the other two phases would be significantly lower.

The values of maximum input current are stated for a supply with a 2 % negative phase-sequence imbalance and rated at the maximum supply fault current given in Table 5-15.

**Table 5-15 Supply fault current used to calculate maximum input currents**

Model	Symmetrical fault level (kA)
All	100



#### Fuses

The AC supply to the drive must be installed with suitable protection against overload and short-circuits. Table 5-16 shows the recommended fuse ratings. Failure to observe this requirement will cause risk of fire.

**Table 5-16 AC Input current and fuse ratings (400 V)**

Model	Typical input current A	Maximum continuous input current A	Maximum overload input current A	Fuse rating					
				IEC			UL / USA		
				Nominal A	Maximum A	Class	Nominal A	Maximum A	Class
11403770	424	449	579	500	500	gR	600	600	HSJ
11404170	455	492	613						
11404640	502	539	752						

**Table 5-17 AC Input current and fuse ratings (575 V)**

Model	Typical input current A	Maximum continuous input current A	Maximum overload input current A	Fuse rating					
				IEC			UL / USA		
				Nominal A	Maximum A	Class	Nominal A	Maximum A	Class
11502000	240	265	327	400	400	gR	400	400	HSJ
11502540	285	310	395						
11502850	313	338	473						

**Table 5-18 AC Input current and fuse ratings (690 V)**

Model	Typical input current A	Maximum continuous input current A	Maximum overload input current A	Fuse rating					
				IEC			UL / USA		
				Nominal A	Maximum A	Class	Nominal A	Maximum A	Class
11602100	225	256	379	400	400	gR	400	400	HSJ
11602380	271	302	425						
11602630	298	329	465						

**Table 5-19 Cable ratings (400 V)**

Model	Cable size (IEC) mm <sup>2</sup>						Cable size (UL) AWG or kcmil			
	Input			Output			Input		Output	
	Nominal	Max	Install method	Nominal	Max	Install method	Nominal	Max	Nominal	Max
11403770	4 x 95		C	2 x 185		C	4 x 3/0		2 x 400	
11404170				2 x 240			4 x 4/0			
11404640				2 x 240			4 x 4/0			

**Table 5-20 Cable ratings (575 V)**

Model	Cable size (IEC) mm <sup>2</sup>						Cable size (UL) AWG or kcmil			
	Input			Output			Input		Output	
	Nominal	Max	Install method	Nominal	Max	Install method	Nominal	Max	Nominal	Max
11502000	2 x 70		C	2 x 70		C	2 x 3/0		2 x 3/0	
11502540	2 x 95			2 x 95			2 x 4/0		2 x 4/0	
11502850	2 x 120			2 x 120			2 x 250		2 x 250	

**Table 5-21 Cable ratings (690 V)**

Model	Cable size (IEC) mm <sup>2</sup>						Cable size (UL) AWG or kcmil			
	Input			Output			Input		Output	
	Nominal	Max	Install method	Nominal	Max	Install method	Nominal	Maximum	Nominal	Max
11602100	2 x 70		C	2 x 70		C	2 x 3/0		2 x 3/0	
11602380	2 x 95			2 x 95			2 x 4/0		2 x 4/0	
11602630	2 x 95			2 x 95			2 x 250		2 x 250	

**NOTE**

The cable sizes noted in Table 5-19 to Table 5-21 are typical cable sizes based on UL508C and IEC60364-5-52:2001. Maximum cable sizes are 2 x 240 mm<sup>2</sup> or 2 x 400 kcmil per pole. The user will have to decide what size of cable to use in any given application based on the local wiring regulations. Use of high temperature cables that are thinner than those stated in the typical cable chart maybe possible, contact the supplier of the drive for advice.

**Installation method (ref:IEC60364-5-52:2001)**

- B1 - Separate cables in conduit
- B2 - Multicore cable in conduit
- C - Multicore cable in free air

**NOTE**

Cable sizes are from IEC60364-5-52:2001 table A.52.C with correction factor for 40 °C ambient of 0.87 (from table A52.14) for cable installation method B2 (multicore cable in conduit).

Cable size may be reduced if a different installation method is used, or if the ambient temperature is lower.

**NOTE** The recommended cable sizes above are only a guide. The mounting and grouping of cables affects their current-carrying capacity, in some cases smaller cables may be acceptable but in other cases a larger cable is required to avoid excessive temperature or voltage drop. Refer to local wiring regulations for the correct size of cables.

A fuse or other protection must be included in all live connections to the AC supply.

**Fuse types**

The fuse voltage rating must be suitable for the drive supply voltage.

**IEC Fuse types**

- IEC class gG - Full range breaking capability in general application. Slow acting.
- IEC class gR - Dual rated: semiconductor protection (ultra-fast acting) and cable protection.
- IEC class aR - Semiconductor Protection, fast acting. Provides no protection from slow, small overloads, so cable must be protected by using a gG fuse or circuit breaker.
- HRC- High Rupturing Capacity – Denotes the ability of the fuse link to interrupt extremely high fault currents.

**North American Fuse Types**

- UL class J - Full range breaking capability in general application. Slow acting. Up to 600 V only.
- Ferraz HSJ -High speed class J fuses. Dual rated: semiconductor protection (ultra-fast acting) and cable protection. Up to 600 V only and only from Ferraz.

**5.1.22 Maximum motor cable lengths**

**Table 5-22 Maximum motor cable lengths**

Model	Maximum permissible motor cable length for each of the following switching frequencies						
	2 kHz	3 kHz	4 kHz	6 kHz	8 kHz	12 kHz	16 kHz
<b>400 V</b>							
11403770	250 m (820 ft)	187 m (614 ft)	125 m (614 ft)	93 m (203 ft)			
11404170	250 m (820 ft)	187 m (614 ft)	125 m (614 ft)	93 m (203 ft)			
11404800	250 m (820 ft)	187 m (614 ft)	125 m (614 ft)	93 m (203 ft)			
<b>575 V</b>							
11502000	250 m (820 ft)	187 m (614 ft)					
11502540	250 m (820 ft)	187 m (614 ft)					
11503020	250 m (820 ft)	187 m (614 ft)					
<b>690 V</b>							
11602100	250 m (820 ft)	187 m (614 ft)					
11602380	250 m (820 ft)	187 m (614 ft)					
11602770	250 m (820 ft)	187 m (614 ft)					

- Cable lengths in excess of the specified values may be used only when special techniques are adopted; refer to the supplier of the drive.
- The default switching frequency is 3 kHz for Open-loop and RFC-A and 6 kHz for RFC-S mode.

The maximum cable length is reduced from that shown in Table 5-22 if high capacitance or reduced diameter motor cables are used. For further information, refer to *section 4.10.2 High-capacitance / reduced diameter cables* on page 52.

Table 5-23 Minimum resistance values and peak power rating for the braking resistor at 40 °C (104 °F)

Model	Minimum resistance* Ω	Instantaneous power rating kW	Continuous power rating kW
<b>400 V</b>			
11403770	1.83	369.4	185
11404170	1.2	563.4	200
11404640	1.2	563.4	250
<b>575 V</b>			
11502000	1.83	525.2	150
11502540	1.83	525.2	185
11502850	1.83	525.2	225
<b>690 V</b>			
11602100	2.2	633.6	185
11602380	2.2	633.6	200
11602630	2.2	633.6	250

\* Resistor tolerance: ±10 %.

### 5.1.23 Terminal size and torque settings

Table 5-24 Drive control and relay terminal data

Model	Connection type	Torque setting
All	Plug-in terminal block	0.5 N m (0.4 lb ft)

Table 5-25 Drive power terminal data

AC terminals	DC and braking	Ground terminal
M10 Nut (17 mm AF)	M10 Nut (17 mm AF)	M10 Nut (17 mm AF)
15.0 N m (11.1 lb ft)	15.0 N m (11.1 lb ft)	15 N m (11.1 lb ft)

## 5.2 Optional external EMC filters

Table 5-26 EMC filter cross reference

Model	CT part number
<b>400 V</b>	
11403770	4200-0400
11404170	4200-0400
11404640	4200-0400
<b>575 V</b>	
11502000	4200-0690
11502540	4200-0690
11502850	4200-0690
<b>690 V</b>	
11602100	4200-0690
11602380	4200-0690
11602630	4200-0690

## 5.2.1 Electromagnetic compatibility (EMC)

This is a summary of the EMC performance of the drive. For full details, refer to the *EMC Data Sheet* which can be obtained from the supplier of the drive.

**Table 5-27 Immunity compliance**

Standard	Type of immunity	Test specification	Application	Level
IEC61000-4-2 EN61000-4-2:2009	Electrostatic discharge	6 kV contact discharge 8 kV air discharge	Module enclosure	Level 3 (industrial)
IEC61000-4-3 EN61000-4-3:2006+A2:2010	Radio frequency radiated field	10 V/m prior to modulation 80 - 1000 MHz 80 % AM (1 kHz) modulation	Module enclosure	Level 3 (industrial)
IEC61000-4-4 EN61000-4-4:2012	Fast transient burst	5/50 ns 2 kV transient at 5 kHz repetition frequency via coupling clamp	Control lines	Level 4 (industrial harsh)
		5/50 ns 2 kV transient at 5 kHz repetition frequency by direct injection	Power lines	Level 3 (industrial)
IEC61000-4-5 EN61000-4-5:2014	Surges	Common mode 4 kV 1.2/50 $\mu$ s waveshape	AC supply lines: line to ground	Level 4
		Differential mode 2 kV 1.2/50 $\mu$ s waveshape	AC supply lines: line to line	Level 3
		Lines to ground	Signal ports to ground <sup>1</sup>	Level 2
IEC61000-4-6 EN61000-4-6:2014	Conducted radio frequency	10V prior to modulation 0.15 - 80 MHz 80 % AM (1 kHz) modulation	Control and power lines	Level 3 (industrial)
IEC61000-4-11 EN61000-4-11:2004	Voltage dips and interruptions	-30 % 10 ms +60 % 100 ms -60 % 1 s <-95 % 5 s	AC power ports	
IEC61000-6-1 EN61000-6-1:2007	Generic immunity standard for the residential, commercial and light - industrial environment			Complies
IEC61000-6-2 EN61000-6-2:2005	Generic immunity standard for the industrial environment			Complies
IEC61800-3 EN 61800-3:2004+A1:2012	Product standard for adjustable speed power drive systems (immunity requirements)		Meets immunity requirements for first and second environments	

<sup>1</sup> See section *Surge immunity of control circuits - long cables and connections outside a building* on page 72 for control ports for possible requirements regarding grounding and external surge protection

### Emission

The drive contains an in-built filter for basic emission control. An additional optional external filter provides further reduction of emission. The requirements of the following standards are met, depending on the motor cable length and switching frequency.



**Table 5-28 Size 11E emission compliance**

Motor cable length (m)	Switching Frequency (kHz)				
	2	3	4	6	8
Using internal filter:					
10 - 50	C3				
100	C3				C4
Using external filter:					
20	C2				
100	C2		C3		

**Key** (shown in decreasing order of permitted emission level):

- E2R EN 61800-3: 2004+A1:2012 second environment, restricted distribution (Additional measures may be required to prevent interference)
- E2U EN 61800-3: 2004+A1:2012 second environment, unrestricted distribution
- I Industrial generic standard EN 61000-6-4:2007+A1:2011 EN 61800-3: 2004+A1:2012 first environment restricted distribution (The following caution is required by EN 61800-3: 2004+A1:2012)



This is a product of the restricted distribution class according to IEC 61800-3. In a residential environment this product may cause radio interference in which case the user may be required to take adequate measures.

- R Residential generic standard EN 61000-6-3:2007+A1:2011  
EN 61800-3: 2004+A1:2012 first environment unrestricted distribution

EN 61800-3: 2004+A1:2012 defines the following:

- The first environment is one that includes residential premises. It also includes establishments directly connected without intermediate transformers to a low-voltage power supply network which supplies buildings used for residential purposes.
- The second environment is one that includes all establishments other than those directly connected to a low-voltage power supply network which supplies buildings used for residential purposes.
- Restricted distribution is defined as a mode of sales distribution in which the manufacturer restricts the supply of equipment to suppliers, customers or users who separately or jointly have technical competence in the EMC requirements of the application of drives.

## IEC 61800-3 and EN 61800-3: 2004+A1:2012

The 2004 revision of the standard uses different terminology to align the requirements of the standard better with the EC EMC Directive.

Power drive systems are categorized C1 to C4:

Category	Definition
C1	Intended for use in the first or second environments
C2	Not a plug-in or movable device, and intended for use in the first environment only when installed by a professional, or in the second environment
C3	Intended for use in the second environment, not the first environment
C4	Intended for use in the second environment in a system rated at over 400 A, or in a complex system

Note that category 4 is more restrictive than E2R, since the rated current of the PDS must exceed 400 A or the supply voltage exceed 1000 V, for the complete PDS.

## 5.2.2 EMC filter ratings

Table 5-29 Optional external EMC filter details

CT part number	Maximum continuous current		Voltage rating		IP rating	Power dissipation at rated current		Ground leakage		Discharge resistors
	@ 40 °C (104 °F)	@ 50 °C (122 °F)	IEC	UL		@ 40 °C (104 °F)	@ 50 °C (122 °F)	Balanced supply phase-to-phase and phase-to-ground	Worst case	
	A	A	V	V		W	W	mA	mA	
4200-0400	600	551	480	480	00	44	38.5	60.7	275	1.68
4200-0690	403	368	690	N/A	00	28	24.5	25	583	2.72

## 5.2.3 Overall EMC filter dimensions

Table 5-30 Optional external EMC filter dimensions

CT part number	Dimension (mm)						Weight	
	H		W		D		kg	lb
	mm	inch	mm	inch	mm	inch		
4200-0400	135	5.32	386	15.2	260	10.2	14.7	32.41
4200-0690	135	5.32	386	15.2	260	10.2	16.75	36.9

## 5.2.4 EMC filter torque settings

Table 5-31 Optional external EMC Filter terminal data

CT part number	Power connections		Ground connections	
	Max cable size	Max torque	Ground stud size	Max torque
4200-0400	10.5 mm	30 N m (22.1 lb ft)	M12	25 N m
4200-0690				

---

## 6 UL listing information

---

### 6.1 UL file reference

All products covered by this Guide are UL Listed to both Canadian and US requirements. The UL file reference is: NMMS/7.E171230.

Products that incorporate the Safe Torque Off function have been investigated by UL. The UL file reference is: FSPC.E1712304.

### 6.2 Option modules, kits and accessories

All Option Modules, Control Pods and Installation Kits supplied by Nidec Industrial Automation for use with these drives are UL Listed.

### 6.3 Enclosure ratings

#### Open Type

With the exception of free-standing cubicle drives, all models are Open Type as supplied. The drive housing is not rated as a fire enclosure. A separate fire enclosure must be provided.

#### Type 1

When fitted with a conduit box the drives meet the requirements for UL Type 1. Type 1 enclosures are intended for indoor use, primarily to provide a degree of protection against limited amounts of falling dirt.

#### Plenum rating with conduit box

When fitted with a conduit box, the drives comply with the requirements in the Standard for Fire Test for Heat and Visible Smoke Release for Discrete Products and Their Accessories Installed in Air-Handling Spaces, UL 2043.

#### Through-hole mounting

The drives meet the requirements for UL Type 12 when installed inside a Type 12 enclosure with the heatsink through-hole mounted using the sealing kit and the high-IP insert (where provided).

When through-hole mounted, the drives are suitable for use in surrounding air temperatures up to 40 °C.

When the drive is through-panel mounted, the main terminal cover(s) must be removed in order to provide access to the mounting holes. Once the drive has been mounted, the terminal cover(s) can be replaced.

The tightening torque of the securement brackets shall be advised as being 3 N m (26.6 lb.in).

#### Remote Keypads

Remote keypads are UL Type 12 when installed with the sealing washer and fixing kit provided.

### 6.4 Mounting

Drives can be mounted directly onto a vertical surface. This is known as 'surface' or 'standard' mounting. Refer to section 3.4.2 *Surface mounting* on page 25 for further information.

Drives can be installed side by side with recommended spacing between them. This is known as 'bookcase' mounting. Refer to section 3.6.1 *Enclosure sizing* on page 28 for further information.

Some drives can be mounted on their side. This is known as 'tile' mounting. Suitable tile mounting kits are available from Nidec Industrial Automation.

Drives fitted with a conduit box can be mounted directly onto a wall or other vertical surface without additional protection. Suitable conduit boxes are available from Nidec Industrial Automation.

Some drives may be through-hole mounted. Mounting brackets and sealing kits are available from Nidec Industrial Automation. Refer to section 3.4.3 *Through-panel mounting* on page 26 for further information.

Remote Keypads can be mounted on the outside of a UL Type 12 enclosure. A sealing and mounting kit is provided with the keypad.

## 6.5 Environment

Drives must be installed in a Pollution Degree 2 environment or better (dry, non-conductive pollution only).

All drives are capable of delivering full rated output current at surrounding air temperatures up to 40 °C

Drives may be operated in surrounding air temperatures up to 50 °C or 55 °C at de-rated current, depending on the model number. Refer to Chapter 5 *Technical data* on page 74.

## 6.6 Electrical Installation

### TERMINAL TORQUE

Terminals must be tightened to the rated torque as specified in the Installation Instructions. Refer to section 3.11 *Terminal size and torque settings* on page 36 for further information.

### WIRING TERMINALS

Drives must be installed using cables rated for 75 °C operation, copper wire only.

UL Listed closed-loop connectors sized according to the field wiring shall be used for all field wiring connections. Refer to section 4.2 *Ground connections* on page 44 for further information.

### BRANCH CIRCUIT PROTECTION

The fuses and circuit breakers required for branch circuit protection are contained in the Installation Instructions. Refer to section 4.9 *Ratings* on page 51.

### OPENING OF BRANCH CIRCUIT

Opening of the branch-circuit protective device may be an indication that a fault has been interrupted. To reduce the risk of fire or electric shock, the equipment should be examined and replaced if damaged. If burnout of the current element of an overload relay occurs, the complete overload relay must be replaced.

Integral solid state short circuit protection does not provide branch circuit protection. Branch circuit protection must be provided in accordance with the National Electrical Code and any additional local "codes".

## 6.7 Motor overload protection and thermal memory retention

All drives incorporate internal overload protection for the motor load that does not require the use of an external or remote overload protection device.

The protection level is adjustable and the method of adjustment is provided in the *Control User Guide*. Maximum current overload is dependent on the values entered into the current limit parameters (motoring current limit, regenerative current limit and symmetrical current limit entered as percentage) and the motor rated current parameter (entered in amperes).

The duration of the overload is dependent on motor thermal time constant. The time contact is programmable. The default overload protection is typically set to 150 % of the motor rated current for 60 seconds.

The drives are provided with user terminals that can be connected to a motor thermistor to protect the motor from high temperature, in the event of a motor cooling fan failure.

The method of adjustment of the overload protection is provided in the Installation Instructions shipped with the product.

All models are provided with thermal memory retention.

## 6.8 Electrical supply

The drives are suitable for use on a circuit capable of delivering not more than 100,000 RMS Symmetrical Amperes, at rated voltage when protected by fuses as specified in the Installation Instructions.

Some smaller drives are suitable for use on a circuit capable of delivering not more than 10,000 RMS Symmetrical Amperes, at rated voltage when protected by circuit breakers as specified in the Installation Instructions.

## 6.9 External Class 2 supply

The external power supply used to power the 24 V control circuit shall be marked: "UL Class 2". The power supply voltage shall not exceed 24 Vdc.

## 6.10 Requirement for Transient Surge Suppression

This requirement applies to drives with rated input voltage = 575 V, Frame Size 7 only.

TRANSIENT SURGE SUPPRESSION SHALL BE INSTALLED ON THE LINE SIDE OF THIS EQUIPMENT AND SHALL BE RATED 575 Vac (PHASE TO GROUND), 575 Vac (PHASE TO PHASE), SUITABLE FOR OVERVOLTAGE CATEGORY III, AND SHALL PROVIDE PROTECTION FOR A RATED IMPULSE VOLTAGE TO WITHSTAND VOLTAGE PEAK OF 6 kV AND A CLAMPING VOLTAGE OF MAXIMUM 2400 V.

## 6.11 Group Installation and Modular Drive Systems

Drives with DC+ and DC- supply connections, with 230 V or 480 V supply voltage rating, are UL approved for use in modular drive systems as inverters when supplied by the converter sections: Mentor MP25A, 45A, 75A, 105A, 155A or 210A range manufactured by Nidec Industrial Automation. Alternatively, the inverters may be supplied by converters from the Unidrive-M range manufactured by Nidec Industrial Automation.

In these applications the inverters are required to be additionally protected by supplemental fuses.

Drives have not been evaluated for other Group Installation applications, for example where a single inverter is wired directly to two or more motors. In these applications, additional thermal overload protection is needed. Contact Nidec Industrial Automation for further details.



**0478-0266-04**